

ZEN Active US

standalone

11.81" x 92.5" h.33.4"

Technical features

Max water capacity	660 gal
Whirlpool jets	40
Airpool jets	47

Dimensional features

Packaging volume	243.6 ft ³
Dry weight	1058 lb
Wet weight	6569.7 lb

Electrical features

Voltage	2 x 120 volt
Amperage	51.74 A
Tension	60 Hz
WHIRLPOOL absorbed power	2.76 Kw motor 1 2.76 Kw motor 2
RECIRCULATION absorbed power	0.15 Kw
Temperature controller	5.5 Kw
AIRPOOL motor power	800 watt
Maximum total absorption	11.9 Kw

Technical drawing

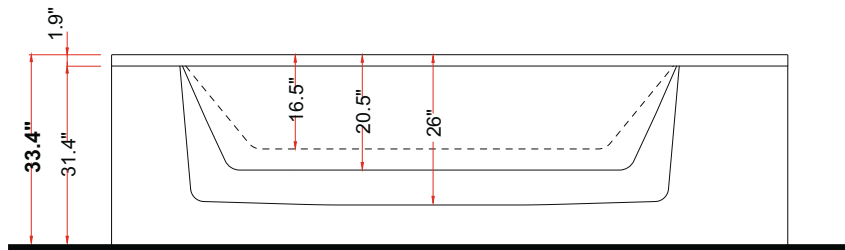
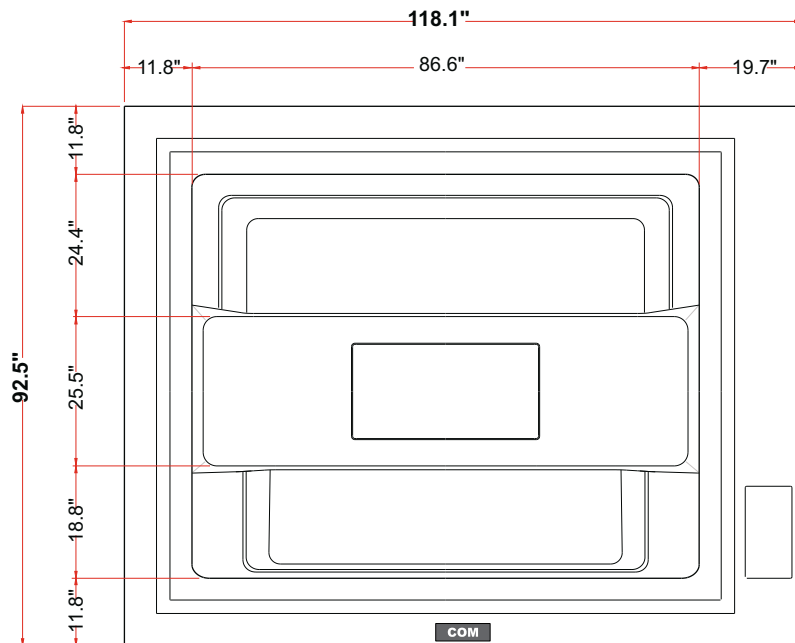

COM Control panel

Installations allowed

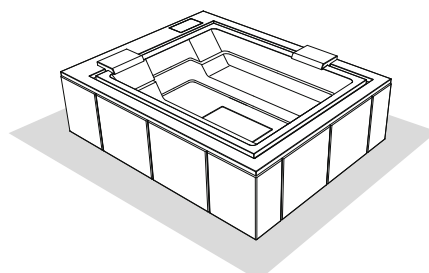

standalone

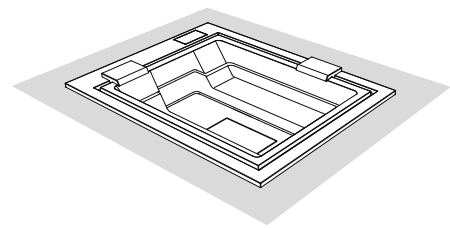

built-in standalone

ZEN Active

11.81" x 92.5" h.33.4"

Hydraulic installation - Electrical installation

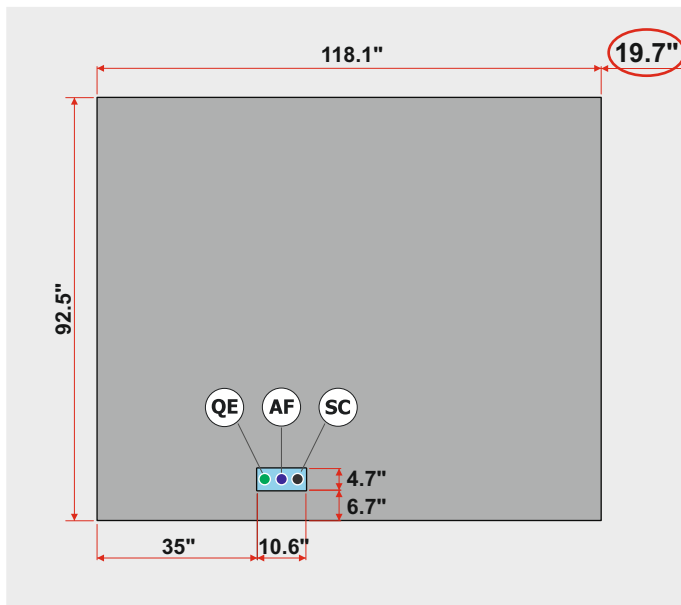

standalone - mandatory empty perimeter area

built-in - mandatory area for technical room for inspection

The connections must be placed inside the blue area

AF Cold water connection - 1/2" inch

SC Recommended floor drain Ø40mm

QE Electrical connection



It is recommended to install upstream of the hydraulic system of filter faucets. The company declines problems arising from failure to install them

NOTE

- The electrical system to which the mini-pool will be connected must comply with CEE standards
- **The minipool should be connected to a mains isolator (magnetothermic switch) with min. 3mm spaced contacts and an RCD (differential switch) of max 30mA**
- It is necessary that the building electrical system is equipped with a bipolar disconnecting device
- The electrical system must be equipped with an efficient ground system
- The minipool must be connected to the building's ground system permanently

Main components

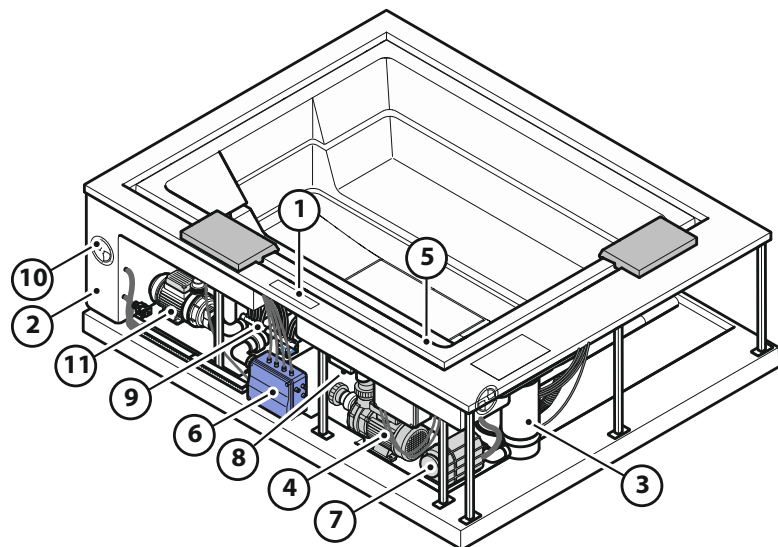

- 1 Control panel
- 2 Compensation tank
- 3 Paper filter
- 4 Whirlpool pump 1
- 5 Overflow
- 6 Control units
- 7 Blower pump
- 8 Heater
- 9 Ozonizator
- 10 Inspection of compensation tank
- 11 Circulation pump

ZEN Active

11.81" x 92.5" h.33.4"

Free-standing installation

standalone - mandatory empty perimeter area

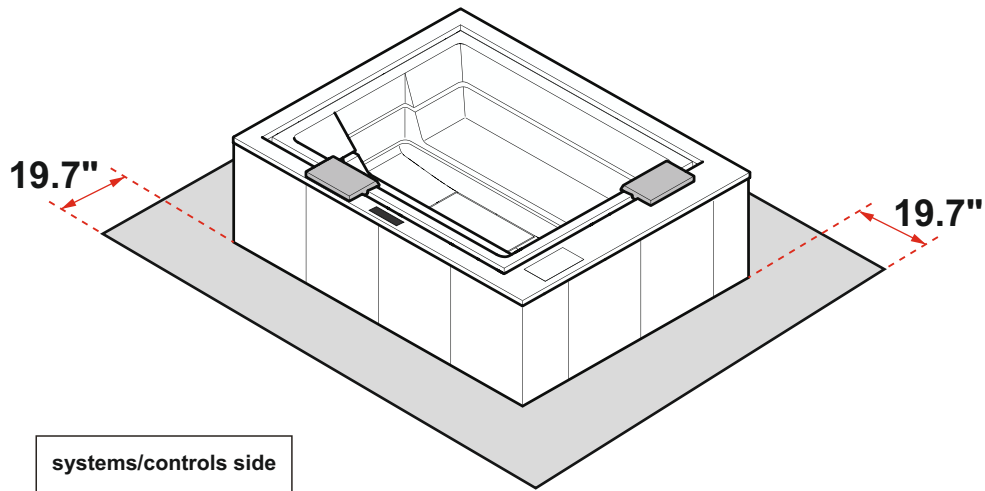

Preparation of the installation site

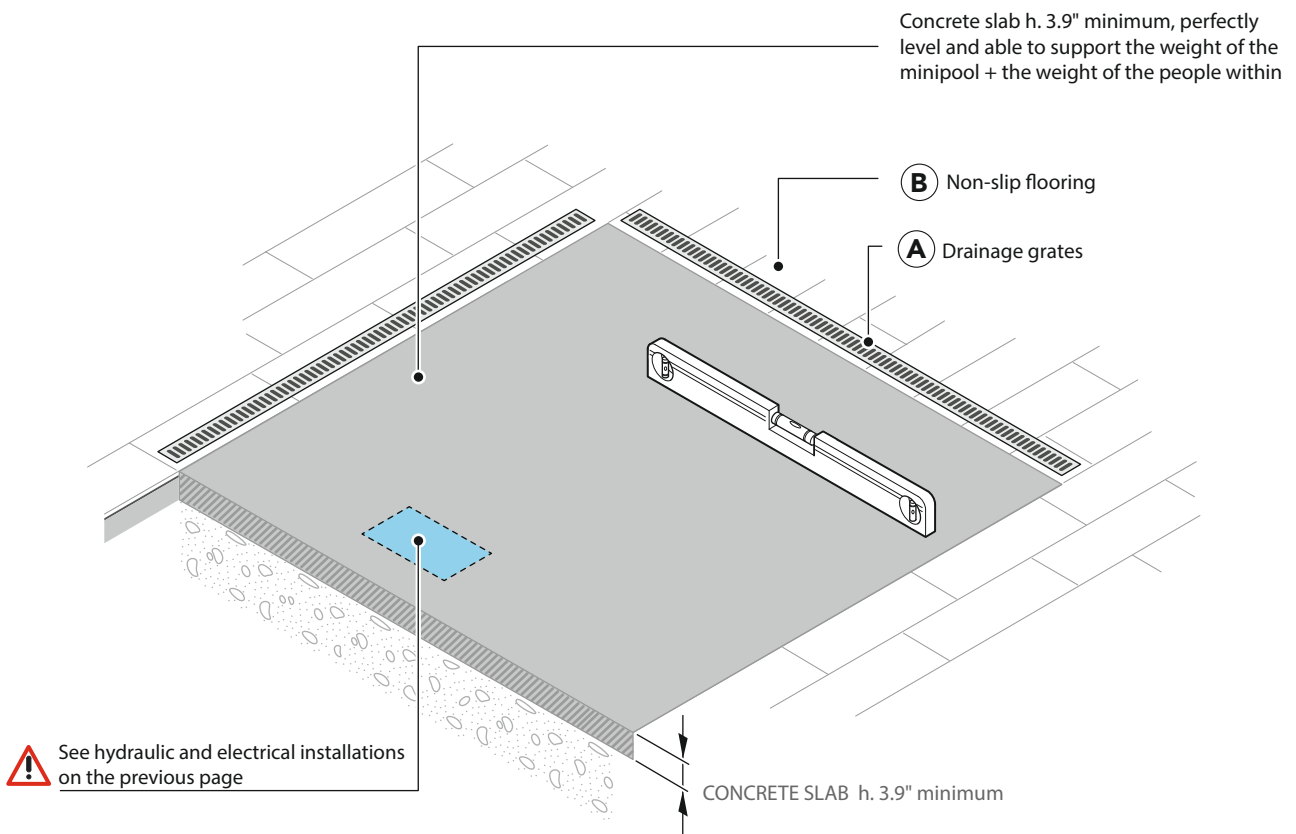

ZEN Active

11.81" x 92.5" h.33.4"

Built in installation

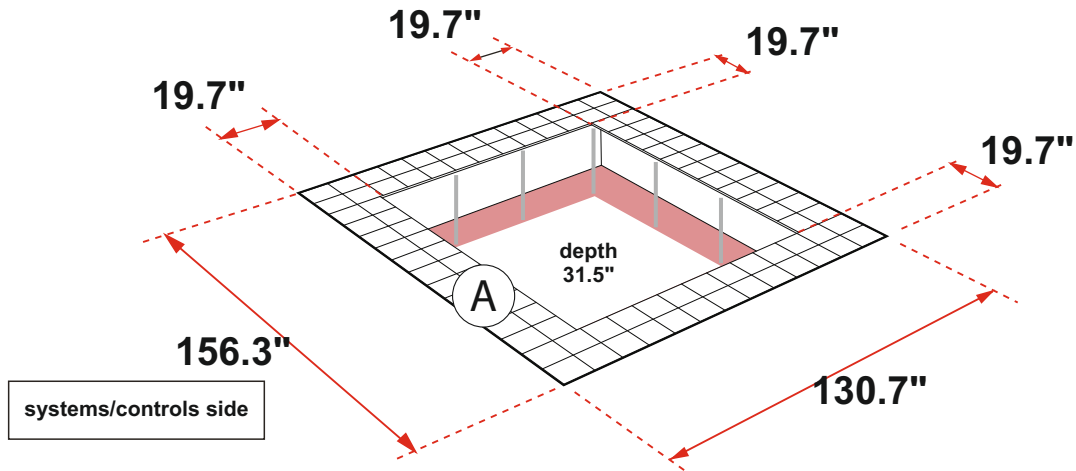

A INSPECTION COMPARTMENT DETAILS

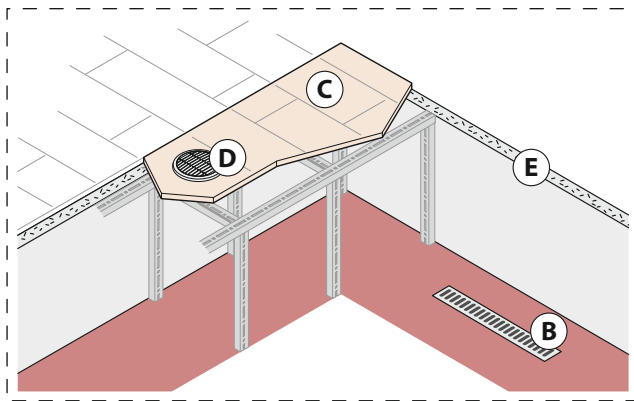

- A** Perimetric inspection compartment of 19.7" with removable floor
- B** Internal drainage grates
- C** Non-slip flooring
- D** n°2 Ø5.9" vents to ensure proper ventilation of the technical compartment
- E** Insulation: prevents damage from freezing and condensation

NB: we recommend to let the spa discharge its weight on the base and not on the edges.

We advice to fix the last line of tiles near the edge once the installation is finished, the result will be a good match between the spa and the covering.

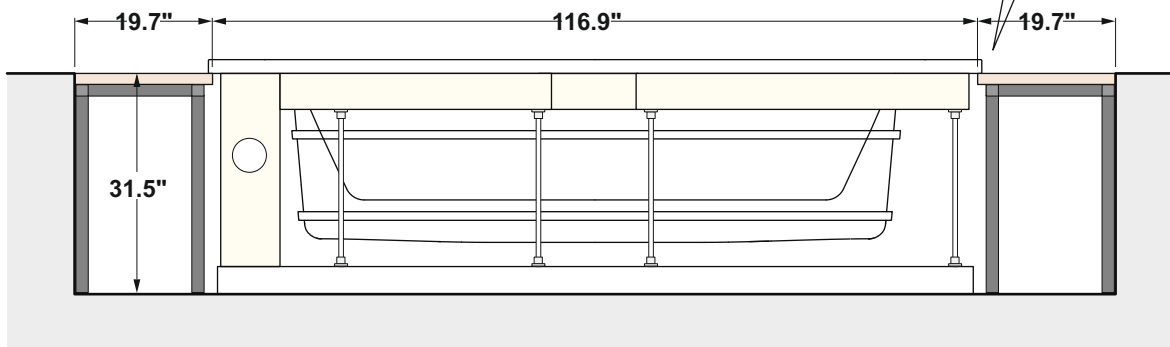
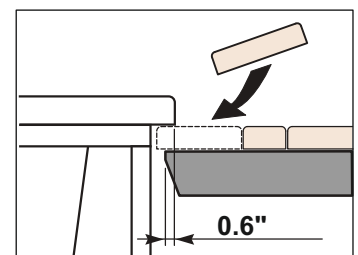

Built in installation with lifter

ZEN Active

11.81" x 92.5" h.33.4"

⚠ ATTENTION

THE AIR CHAMBER OF LIFTER MUST BE ALWAYS ON THE SAME SIDE OF THE CONTROL PANEL OF THE MINIPOOL.

FIXE THE LIFTER TO THE GROUND ONLY AFTER YOU MAKE THE EXCURSION TEST WITH THE SUBFRAME, WITHOUT THE MINIPOOL.

The connections must be placed inside the blue area

- **AF** Cold water connection - 1/2" inch
- **SC** Recommended floor drain Ø40mm
- **QE** Electrical connection

⚠ It is recommended to install upstream of the hydraulic system of filter faucets. The company declines problems arising from failure to install them

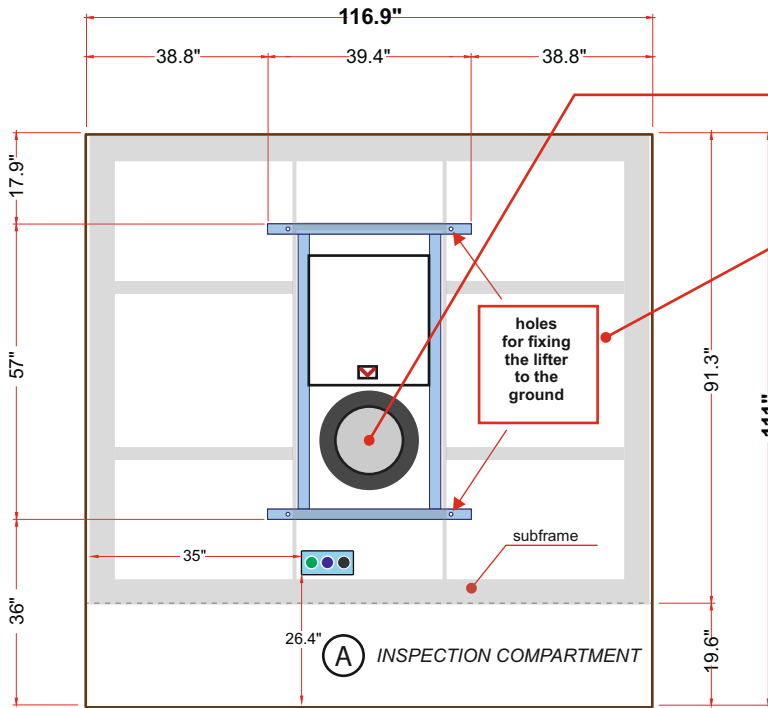

systems/controls side

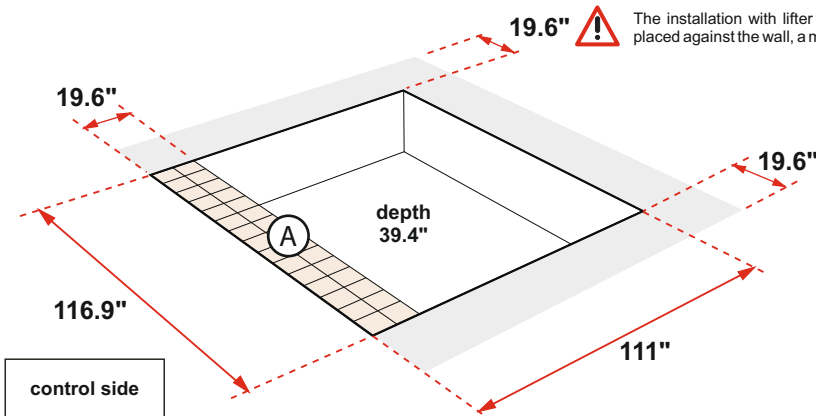

⚠ The installation with lifter is in the center of the room, no side can be placed against the wall, a minimum distance of 19.7" be maintained.

Like built-in installations (see previous pg.) must be installed an internal drainage grates, a non-slip flooring, two vents Ø5.9" to ensure a proper ventilation of the technical compartment and an insulation to prevent damages from freezing and condensation.

(A) INSPECTION COMPARTMENT with removable floor (systems side only)

NB: we recommend to let the spa discharge its weight on the base and not on the edges.

