

WAVE US

standalone

92.5"x92.5" h.38.6"

Technical features

Max water capacity	475 gal.
Whirlpool jets	40
Airpool jets	40

Dimensional features

Packaging volume	226 ft ³
Dry weight	926 lb
Wet weight	4894 lb

Electrical features

Voltage	2 x 120
Amperage	37 A
Frequency	60 Hz
WHIRLPOOL absorbed power	2.76 Kw
RECIRCULATION absorbed power	0.15 Kw
Temperature controller	5.5 Kw
AIRPOOL absorbed power	805 watt

Technical drawing

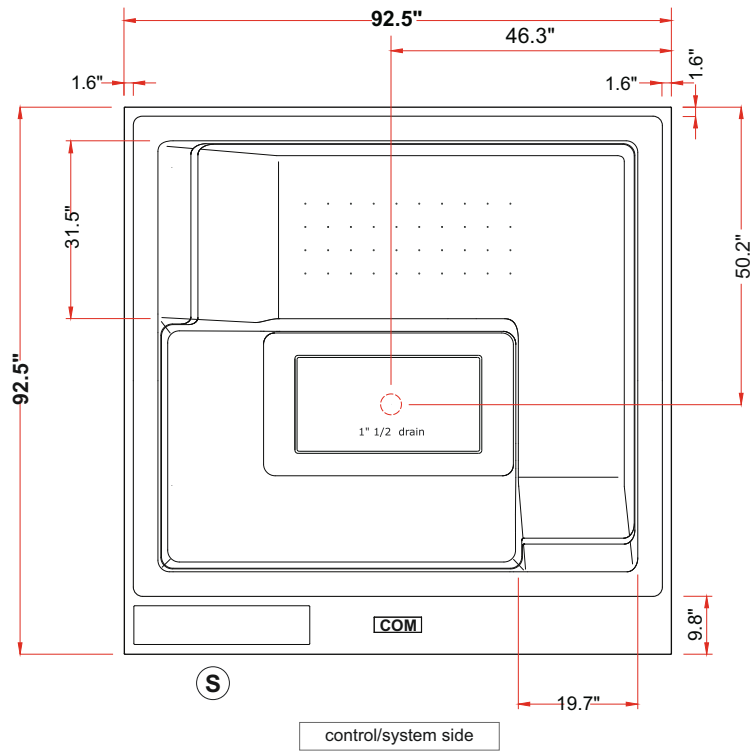

(S) Draining valve

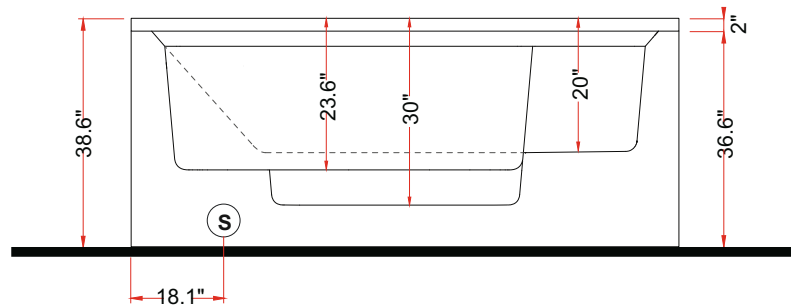

Installations allowed

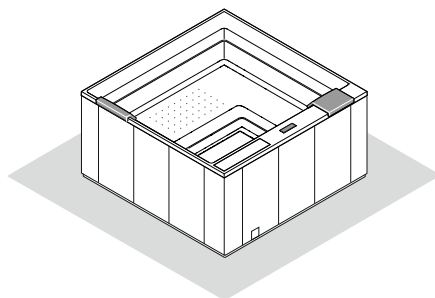

standalone

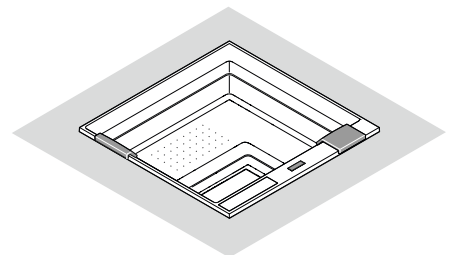

built-in standalone

Hydraulic installation - Electrical installation

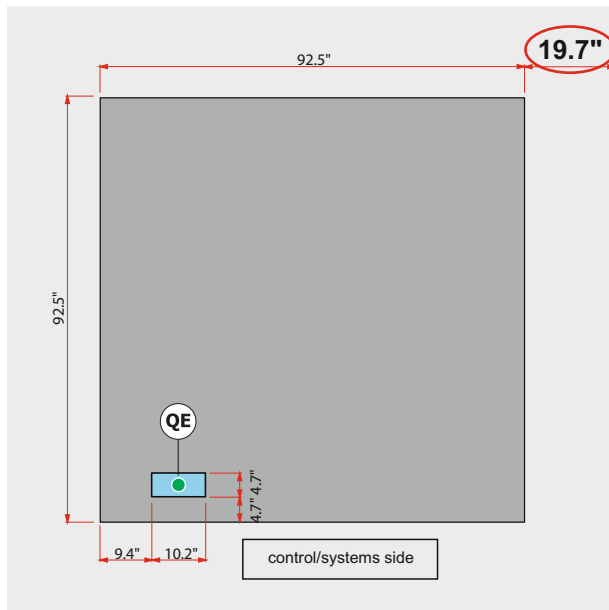

standalone - mandatory empty perimeter area

built-in - mandatory area for technical room for inspection

The connections must be placed inside the blue area

QE Electrical connection

! It is recommended to install upstream of the hydraulic system of filter faucets. The company declines problems arising from failure to install them

NOTE

The electrical system to which the mini-pool will be connected must comply with CEE standards

The minipool should be connected to a mains isolator (magnetothermic switch) with min. 3mm spaced contacts and an RCD (differential switch) of max 30mA

It is necessary that the building electrical system is equipped with a bipolar disconnecting device

The electrical system must be equipped with an efficient ground system

The minipool must be connected to the building's ground system permanently

Main components

- 1 Control panel
- 2 Circulation pump
- 3 Paper filter
- 4 Whirlpool pump 1
- 5 Whirlpool pump 2
- 6 Control units
- 7 blower pump (optional)
- 8 Heater
- 9 Drainage tap
- 10 Ozonizator
- 11 Filter compartment
- 12 Pillows

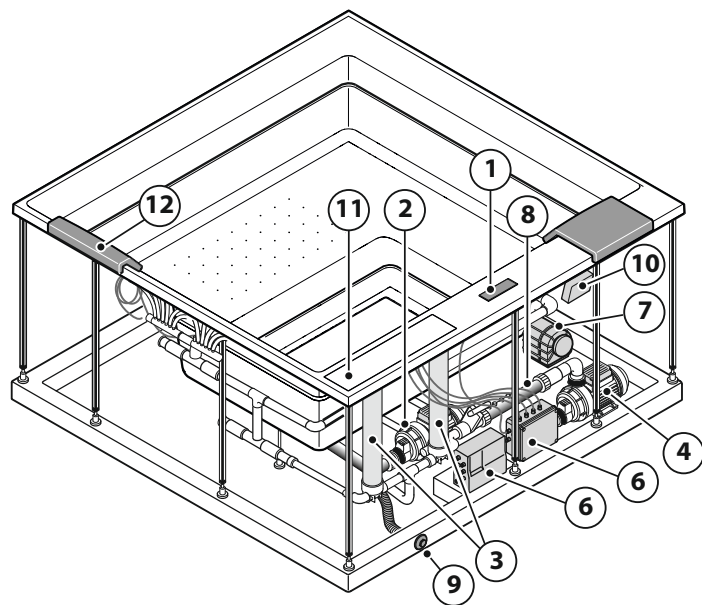

WAVE

92.5"x92.5" h.38.6"

Free-standing installation

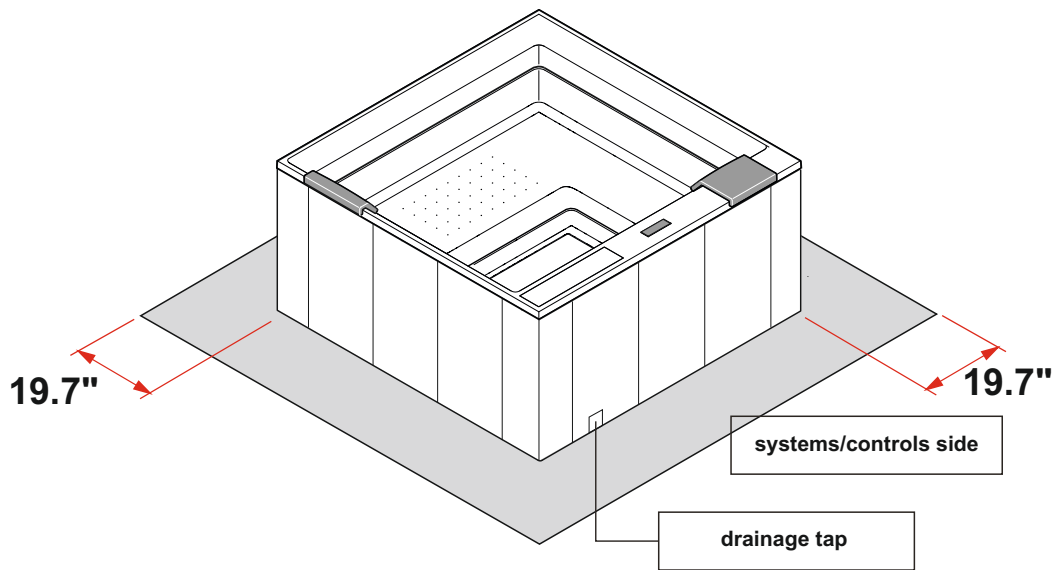

Preparation of the installation site

Concrete slab h. 3.9" minimum, perfectly level and able to support the weight of the minipool + the weight of the people within

B Non-slip flooring

A Drainage grates

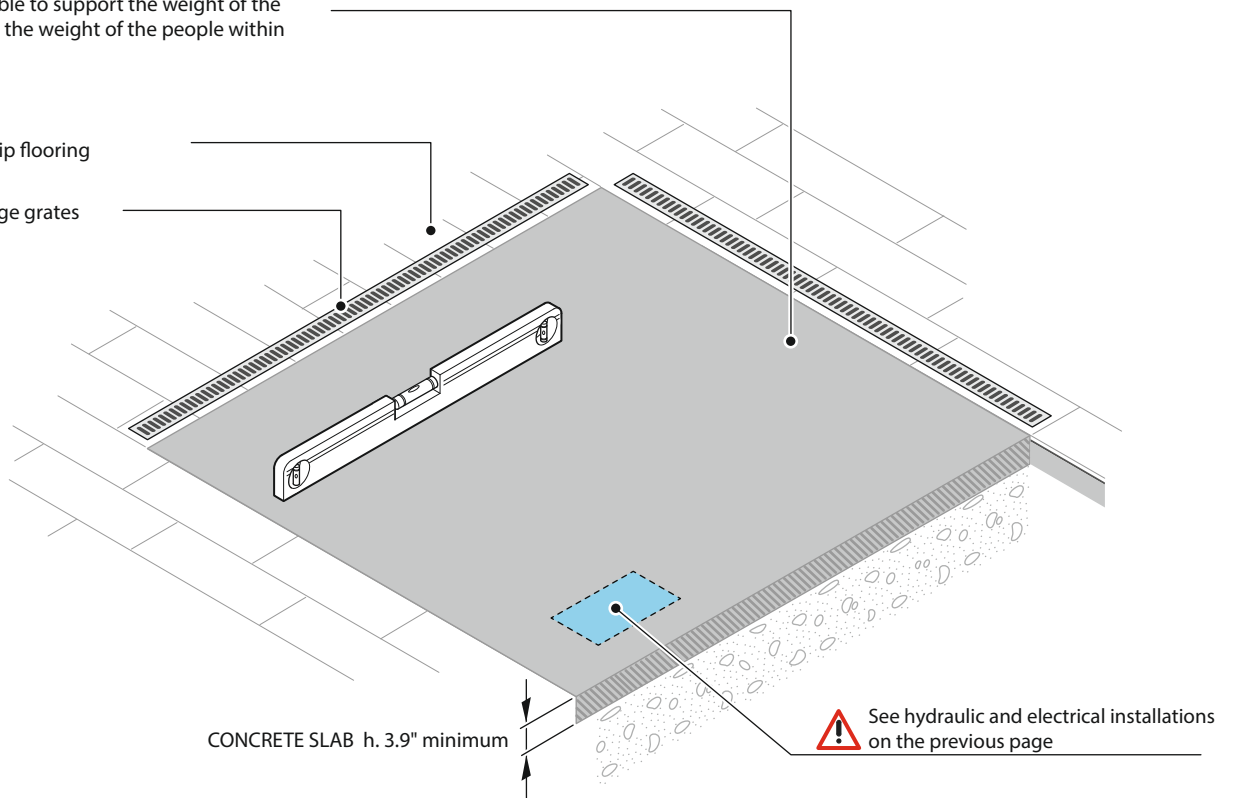

WAVE

92.5"x92.5" h.38.6"

Built in installation

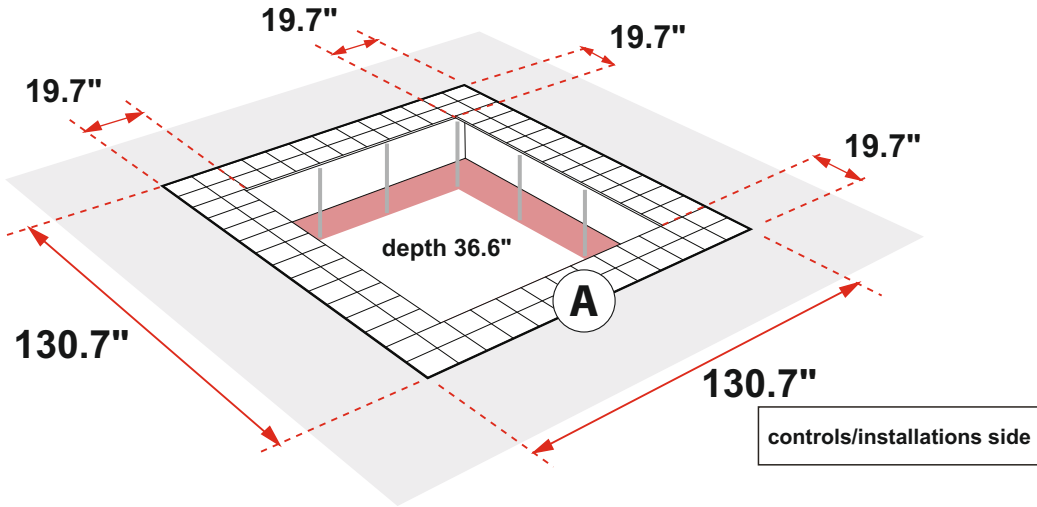

A INSPECTION COMPARTMENT DETAILS

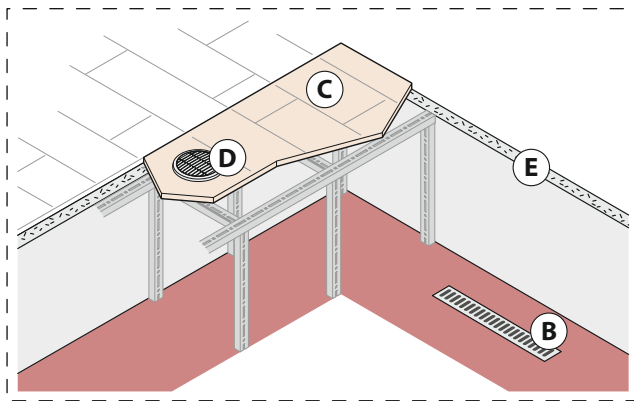

- A Perimetric inspection compartment of 19.7" with removable floor
- B Internal drainage grates
- C Non-slip flooring
- D n°2 Ø5.9" vents to ensure proper ventilation of the technical compartment
- E Insulation: prevents damage from freezing and condensation

NB: we recommend to let the spa discharge its weight on the base and not on the edges.

We advice to fix the last line of tiles near the edge once the installation is finished, the result will be a good match between the spa and the covering.

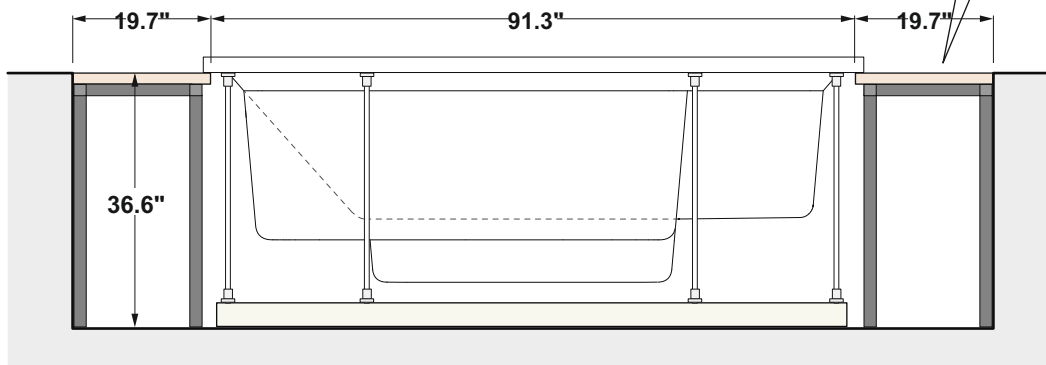
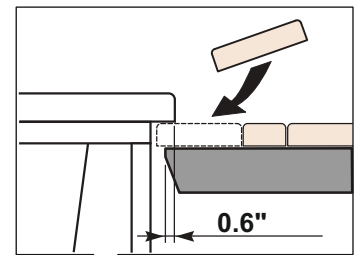

Built in installation with lifter

WAVE

92.5"x92.5" h.38.6"

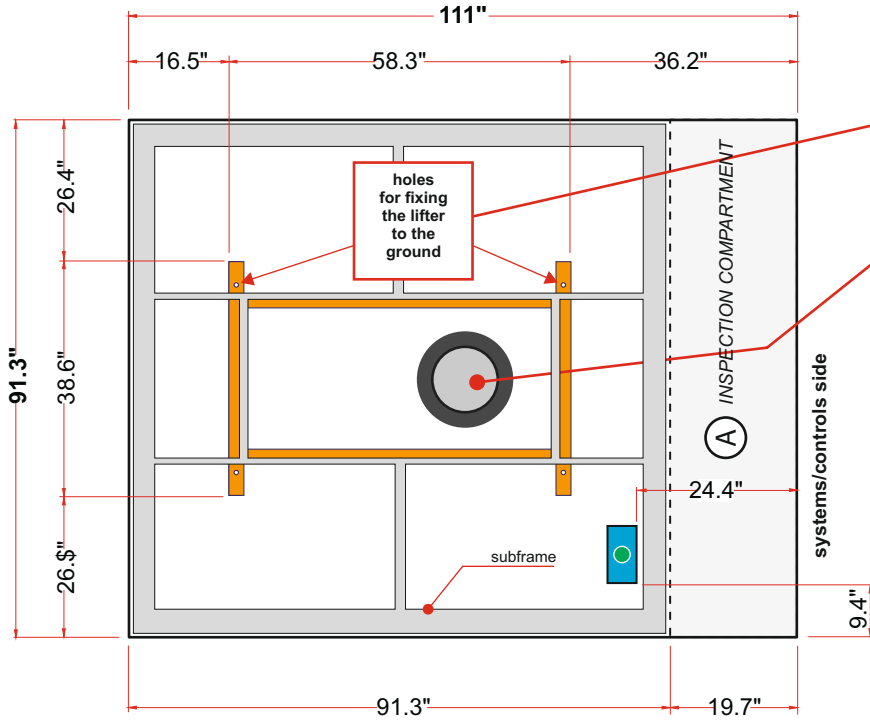

⚠ ATTENTION

THE AIR CHAMBER OF LIFTER MUST BE ALWAYS ON THE SAME SIDE OF THE CONTROL PANEL OF THE MINIPOOL

FIXE THE LIFTER TO THE GROUND ONLY AFTER YOU MAKE THE EXCURSION TEST WITH THE SUBFRAME, WITHOUT THE MINIPOOL.

The connections must be placed inside the blue area

● QE Electrical connection

⚠ It is recommended to install upstream of the hydraulic system of filter faucets. The company declines problems arising from failure to install them

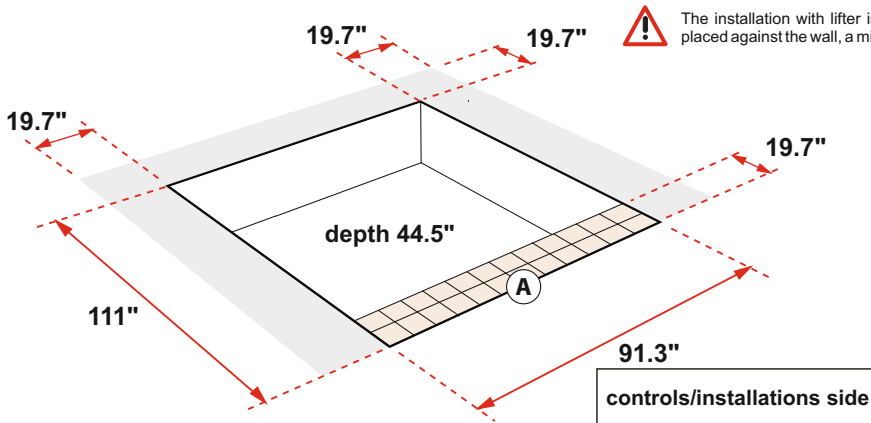

⚠ The installation with lifter is in the center of the room, no side can be placed against the wall, a minimum distance of 19.7" be maintained.

Like built-in installations (see previous pg.) must be installed an internal drainage grates, a non-slip flooring, two vents Ø5.9" to ensure a proper ventilation of the technical compartment and an insulation to prevent damages from freezing and condensation.

Ⓐ INSPECTION COMPARTMENT with removable floor (systems side only)

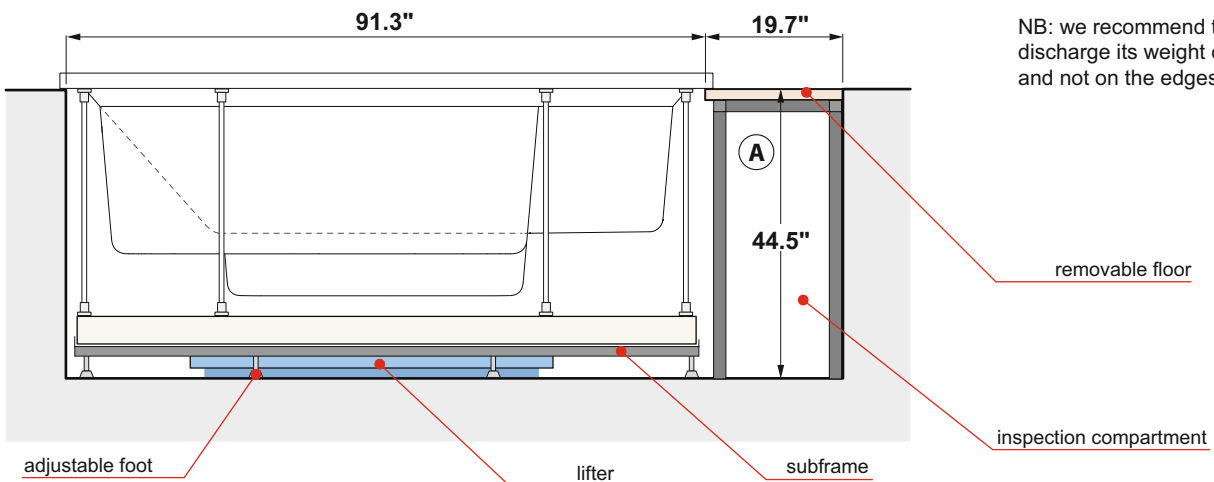

NB: we recommend to let the spa discharge its weight on the base and not on the edges.