

treesse

spa

Shadow



Pre-installation manual

READ AND FOLLOW ALL INSTRUCTIONS

Proper preparation of the premises and systems will ensure a safe and rapid installation of the spa. For this reason we advise you to read this manual carefully and to carefully follow all the information contained herein.

If you have problems, contact your authorised dealer.

Good luck with your work!

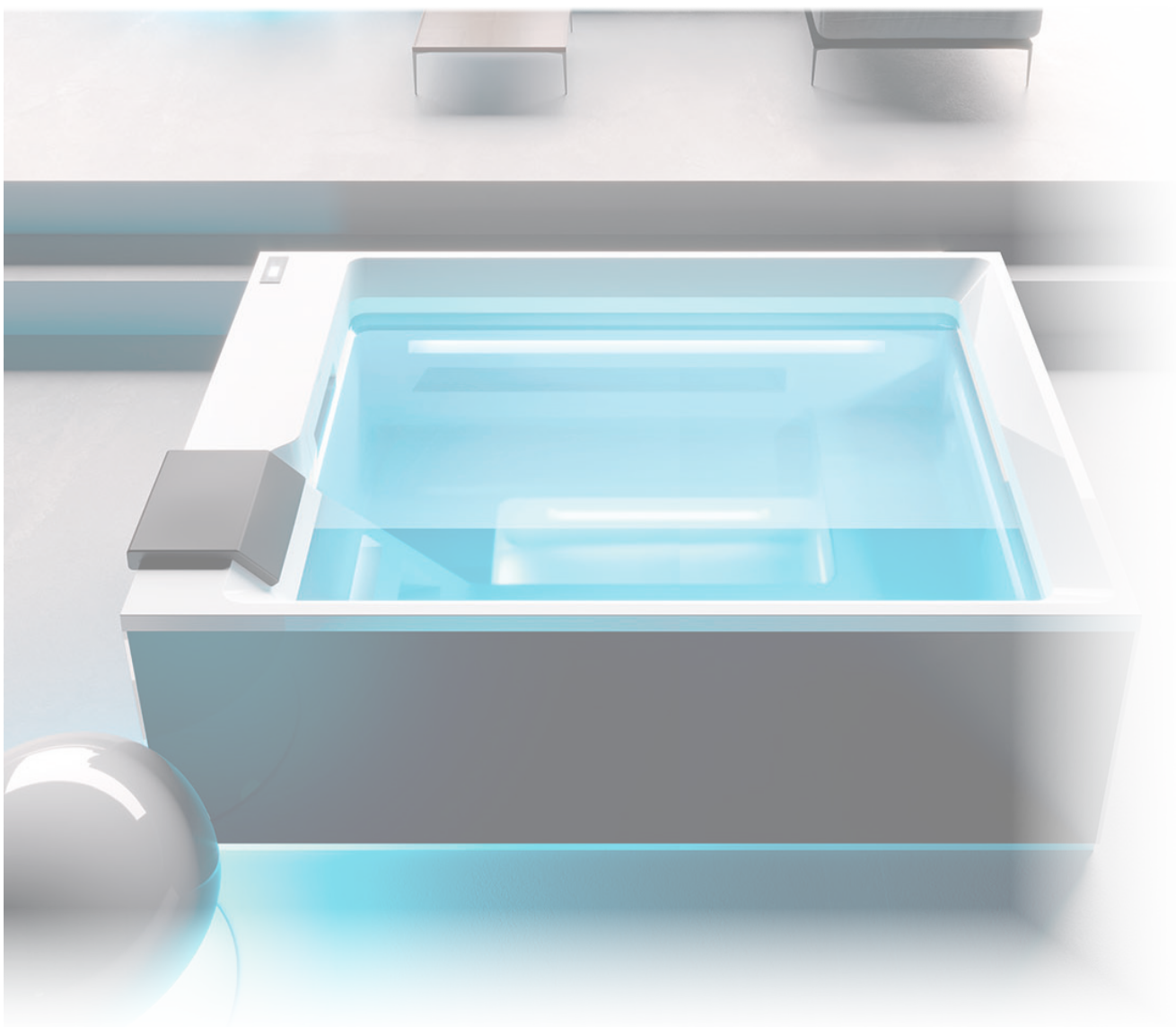

Contents

1	MEASUREMENTS AND TECHNICAL SPECIFICATIONS	4
	TEMPORARY POSITIONING	5
2	WHAT PREPARATIONS ARE REQUIRED?	6
3	IDENTIFICATION OF THE INSTALLATION SITE	9
	OUTDOOR INSTALLATION	9
	INDOOR INSTALLATION	9
	FREESTANDING INSTALLATIONS	10
4	PREPARATION OF THE INSTALLATION SITE	10
5	ELECTRICAL PREPARATIONS	12
6	CHARACTERISTICS OF THE WATER SUPPLY	15
	TAP WATER AND WELL WATER	15
	WATER HARDNESS	15
	WATER ALKALINITY	15
	CHARACTERISTICS OF THE WATER SUPPLY	16

1 SHADOW MEASUREMENTS AND TECHNICAL SPECIFICATIONS

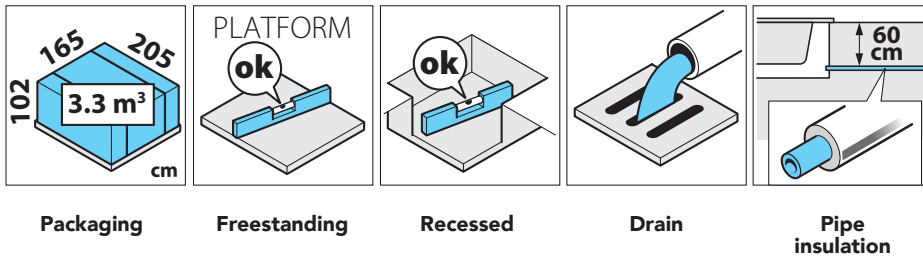

The manufacturer suggests a minimum load of 400 kg/m².

201 x 162 x 83 cm
(79.13 x 63.78 x 32.68 inch.)

maximum water content	1000 litres (264 gal)
weight with water	1220 kg (2690 lb)
weight when empty	220 kg (485 lb)
Volt	2 X 120V
maximum total absorption	7.6 kW
whirlpool motor	2.024 kW
circulation motor	0.69 kW
temperature control	5.5 kW
filtering system	paper
operating temperature	-5°C min +45°C max

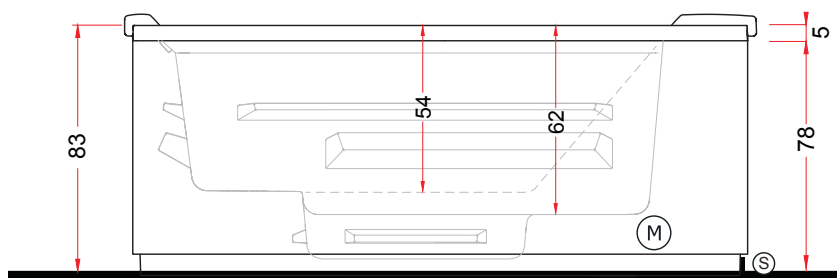
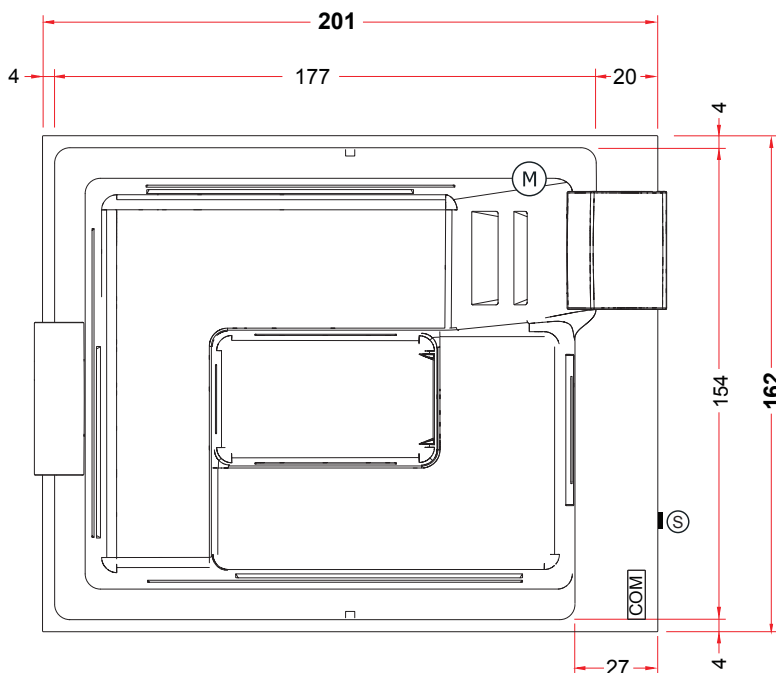

S drain
M whirlpool motor

Size in cm
dimensional tolerances ± 5mm.

The manufacturer reserves the right to make improvements to the equipment at any time, without prior notice.
Partial reproduction without the manufacturer's consent is prohibited. Measurements are purely indicative and not binding.
The original language of this manual is Italian: the Manufacturer is not responsible for any mistakes in translation/interpretation.

The spa works efficiently and safely if it is installed correctly and in compliance with the regulations in force in the country of use.

This pre-installation guide provides information for a proper preparation of the environments and the plumbing and electrical connections.

This allows for a quick and safe installation.

The pre-installation stages involve the following professionals:

- A construction engineer for the calculation of the loading capacity of the platforms or floors.
- A qualified and certified company that will prepare the installation site according to the instructions provided in this guide, following current work safety regulations.
- Certified and qualified electrician who prepares electrical systems in compliance with local and national regulations regarding civil and industrial systems.

The user must promptly notify the professionals of any existing underground obstacles like gas or water lines and electrical or telephone cables.

Upon completion of pre-installation all these specialists must issue a declaration of conformity of the systems installed. Without such document, the Manufacturer declines any responsibility for damage to the systems or premises where the spa will be installed.



We recommend checking with the appropriate municipal offices to see if there are constraints that prevent installation or if permits are required.



An incorrect pre-installation could cause structural damage to the spa and void the warranty.

TEMPORARY POSITIONING



The installation of the spa should be done immediately upon receipt.

In any case, once unpacked, if it is necessary to temporarily place it on a surface awaiting the installation, it will be necessary to place level concrete slabs having a minimum thickness of 5 cm under the entire bottom of the spa.

Since the temporary base may shift, it is recommended to leave the spa in that position for the shortest possible time.

Do not leave the empty spa in DIRECT SUNLIGHT. The surface temperature could rise above 80°C resulting in serious damage, including cavitation and the deformation of the surface and components. Damage caused by direct exposure to sunlight is not covered by the warranty. In such conditions place a cover (fixed or mobile) to protect the spa.

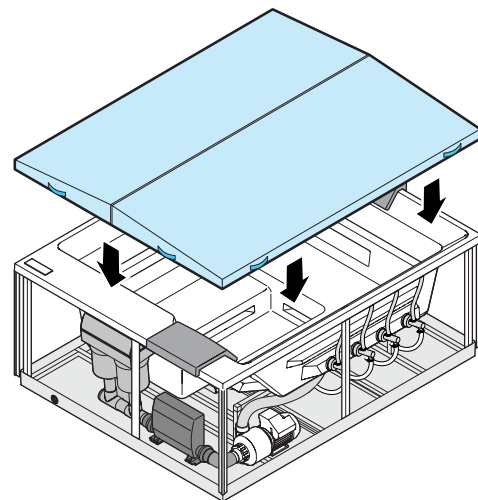
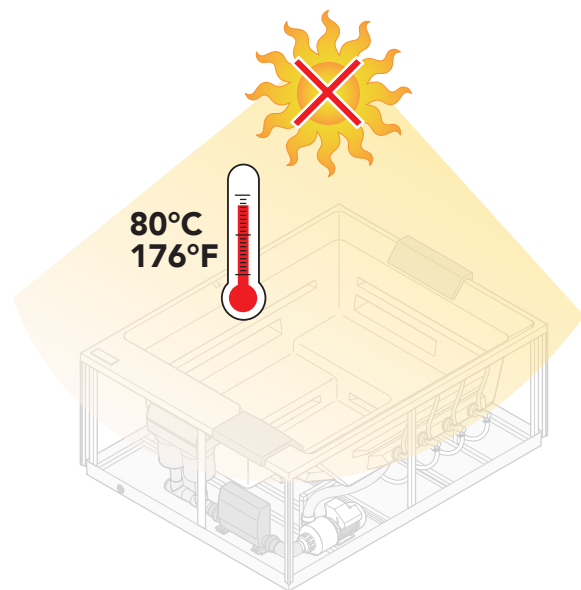

Please note

The Manufacturer cannot be held responsible and **does not recognise the warranty** in the case of:

- **Installations or connections that are not compliant** or that are carried out without following the national regulations concerning civil and industrial installations.
- **Pre-installation and installation carried out by unqualified personnel** or otherwise **not in compliance** with the instructions in the pre-installation and installation manuals.
- **Incorrect preparation of the installation environments**, including the supporting surface.
- **accidents and damage** due to a non-compliant installation or use of the bathtub;
- **Masonry works** that prevent the removal and handling of the spa or defective parts thereof.

2 WHAT PREPARATIONS ARE REQUIRED?

To be installed, the spa requires:

- 1 Identification of the installation site see page 9;
- 2 Preparation of the installation site see page 10;
- 3 prepare the drain following the stated measurements see page 7;
- 4 prepare the electrical system. see page 12.

The following pages will provide detailed explanations of how to perform these preparations.

EXAMPLES SHOWING THE INSTALLATION OF AN OUTDOOR/INDOOR SPA

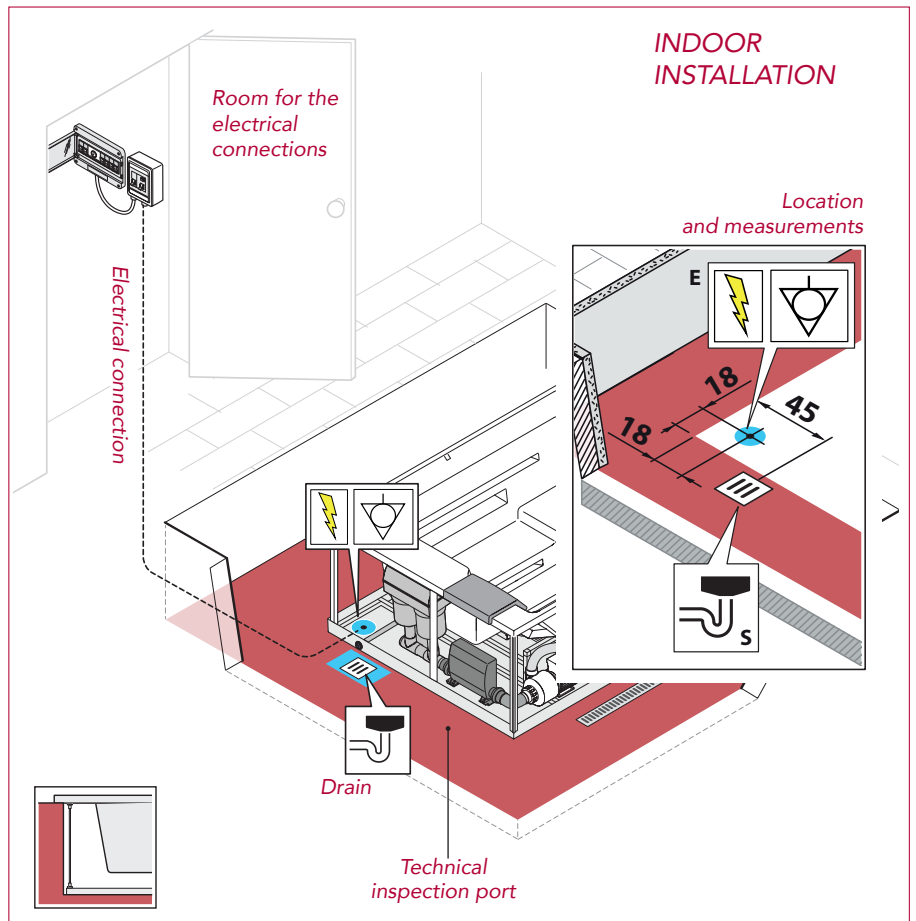
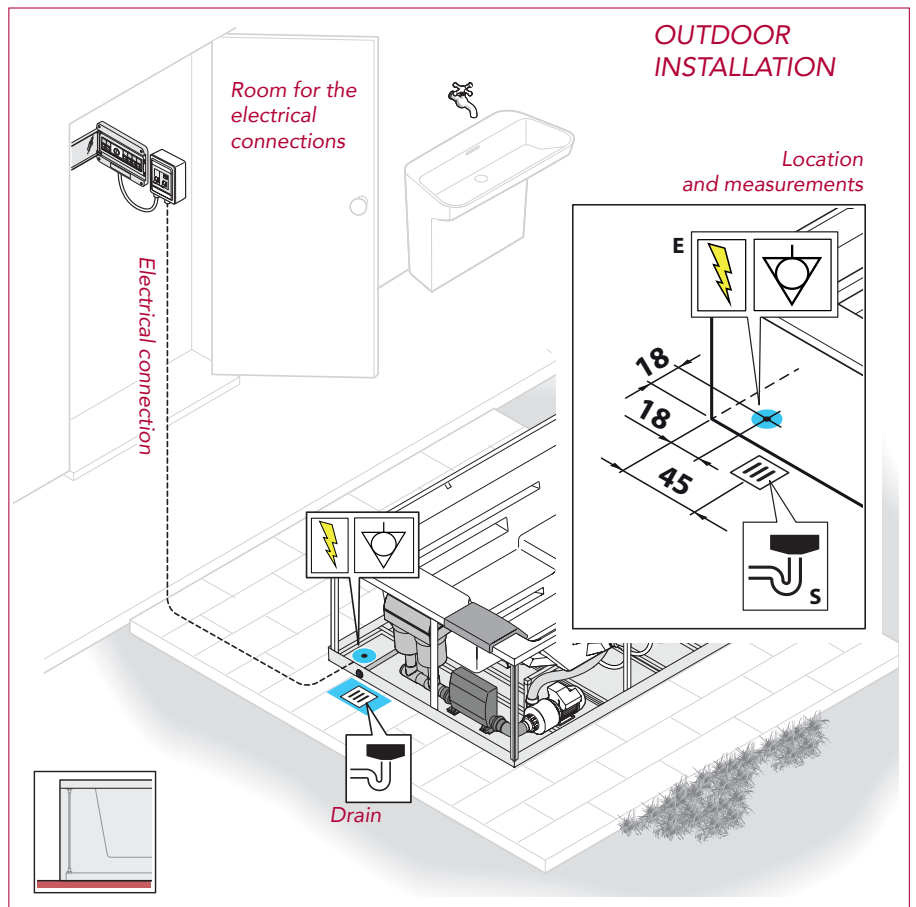

PREPARATION OF CONNECTION TO AN OPTIONAL EXCHANGER (NOT SUPPLIED)

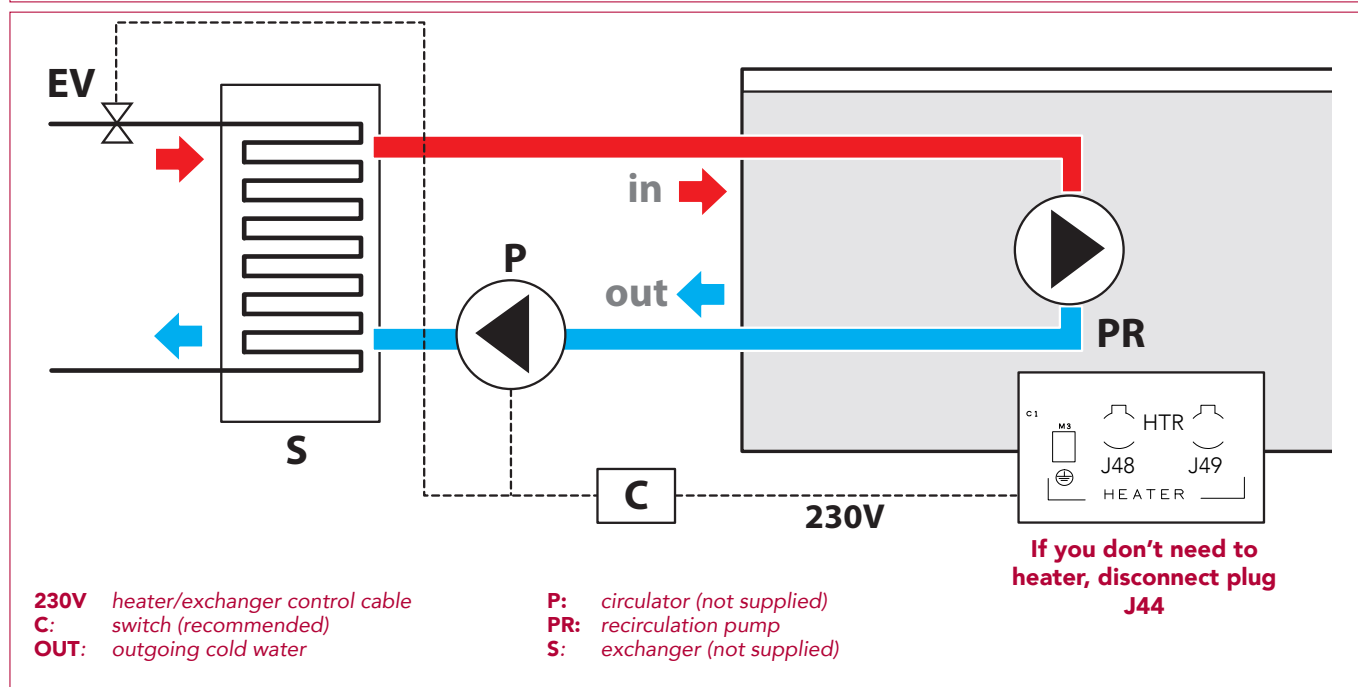
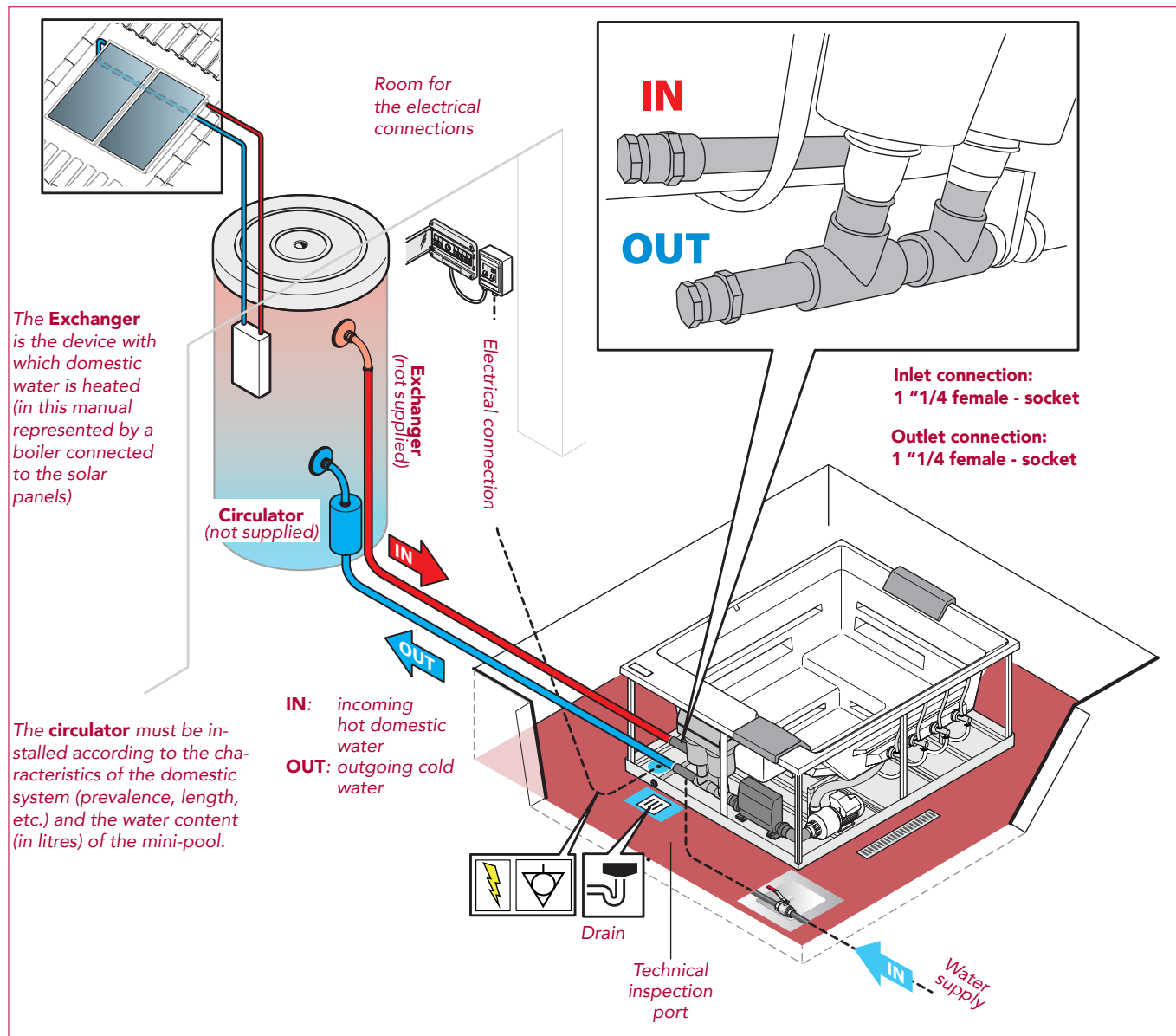



The pipes for connecting to the CLIM8ZONE™ are not included

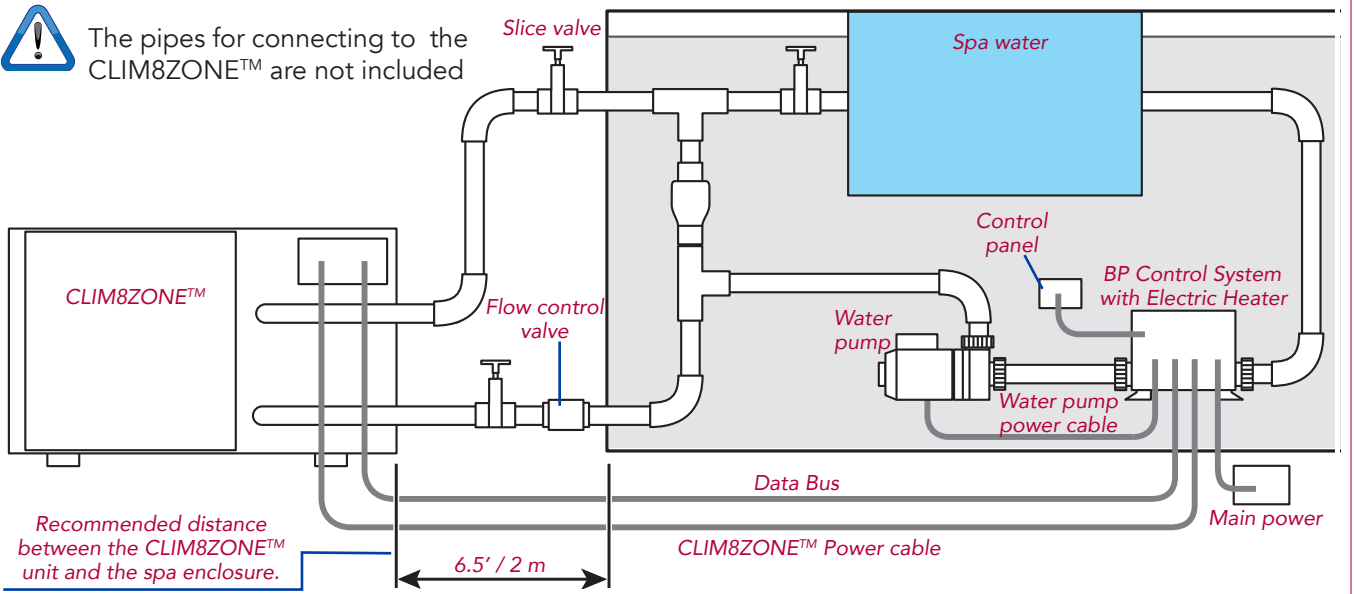

CLIM8ZONE MINIMUM CLEARANCES

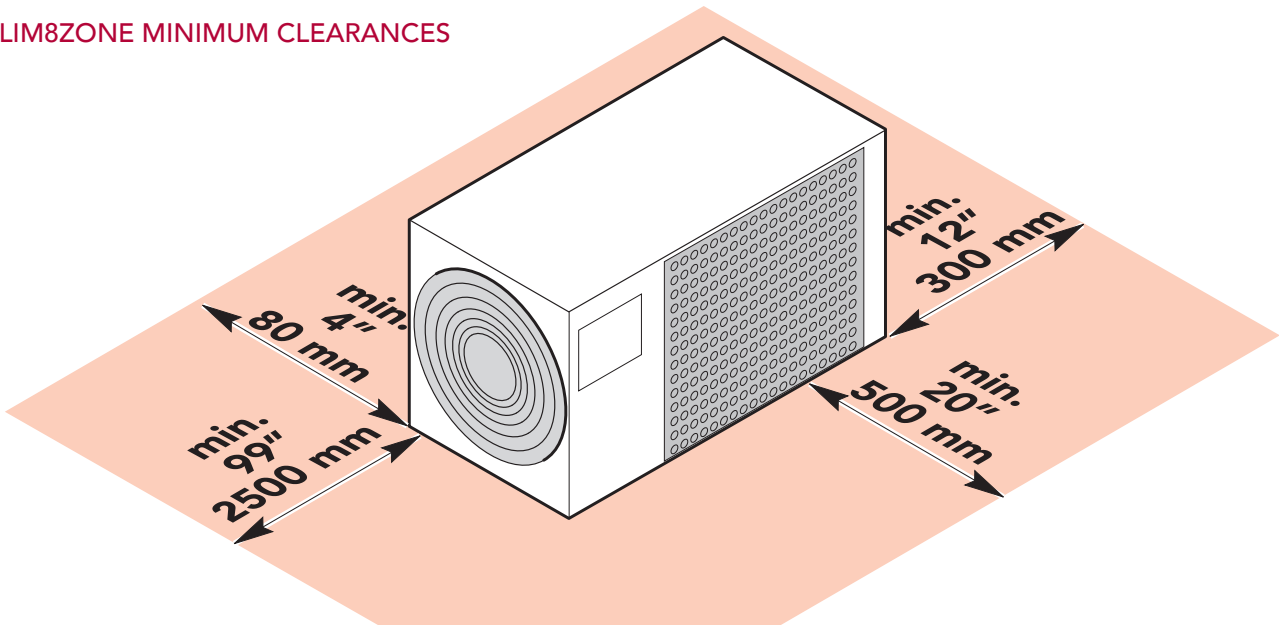

CLIM8ZONE DIMENSIONS

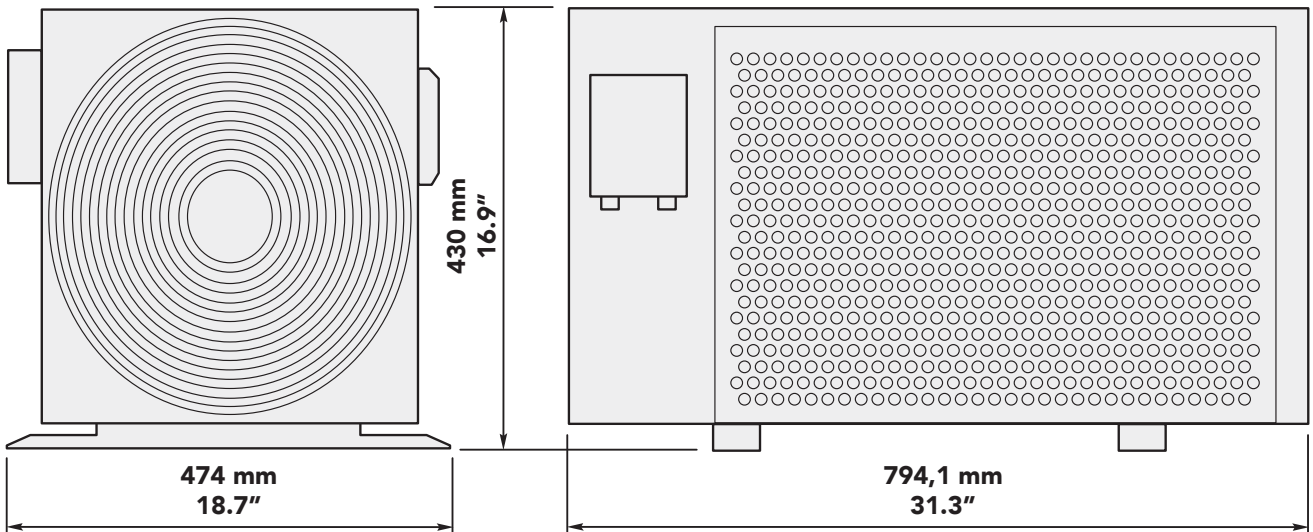

3 IDENTIFICATION OF THE INSTALLATION SITE

 When choosing the position, take into account the local regulations that prohibit any electrical installation (plug sockets, switches, lamps, etc.) in the area surrounding the spa for a distance of at least 60 cm and a height of 230 cm.

 When choosing the position, bear in mind that the inspection side (electrical/plumbing components side) must always remain accessible for future maintenance.

The recommended ambient temperature for the spa must be between -5°C and 45°C , with a relative humidity of 20-80%.

OUTDOOR INSTALLATION

Take into account the proximity of trees or hedges, and note that debris (e.g., leaves) can cause damage to the equipment over time that is not covered by warranty and make maintenance more expensive and frequent.

Also assess the best position to safeguard privacy and respect for others, as well as the best view or climatic position consistent with local regulations.

A sunny area with increased exposure during the morning ensures greater well-being for users!

 Consider the geological composition of the soil on which the supporting platform will be built. Soils that are very sandy, permeable or subject to flooding could compromise the durability of the spa's support platform.

INDOOR INSTALLATION

Note that the evaporation of water in the spa in the presence of high internal temperatures can generate very high levels of humidity in the environment.

To overcome this drawback, choose an environment with good natural or forced ventilation. As an alternative, install a dehumidification system. Humidity damage is not covered by the manufacturer warranty.

 Take into account the size of the spa: narrow passages, doors and steps can be an obstacle to its transport to the desired place.

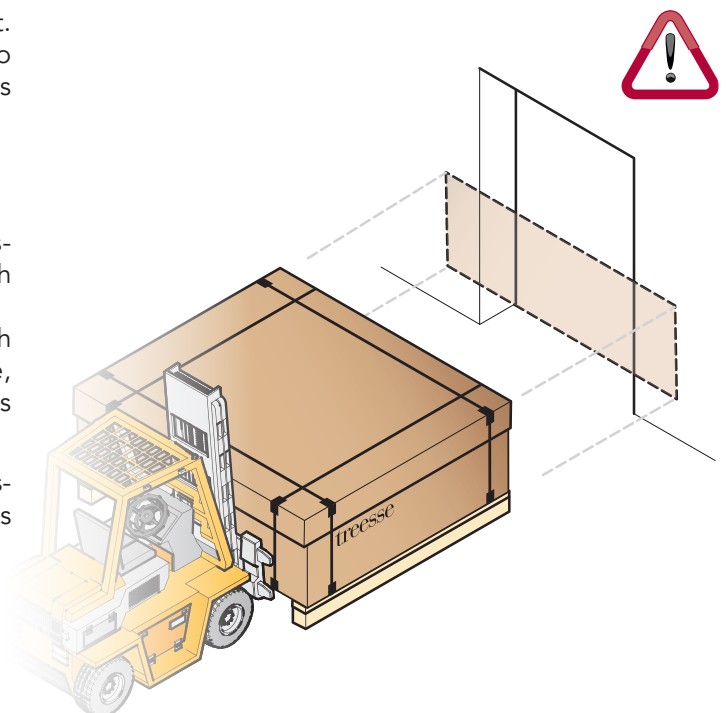

Treesse spas are built to be positioned outdoors.

If you install the spa inside, remember that it must be able to be easily inspected or moved for any ordinary and extraordinary maintenance operations.

4

PREPARATION OF THE INSTALLATION SITE



Before preparing the supporting surface, **see the sections on the electrical connections** for positioning the connections correctly.

FREESTANDING INSTALLATIONS

As a base, build a platform or flooring in reinforced concrete, at least 10 cm thick, perfectly flat and suitable for supporting the weight of the spa and the people using it. The manufacturer suggests a minimum load of 400 kg/m². In any case contact a qualified construction engineer to calculate the appropriate load for the installation site.



Wedges or shims cannot be placed under the spa to level it.

Remember to ground the structural reinforcement in accordance with electrical codes.



Prepare:

- **A** drainage grating around the perimeter to help preserve the equipment and the structure (even for indoor installations).
- **B** A non-slip flooring around the spa.



For the preparation of the electrical connections see the pertinent section on page 12.

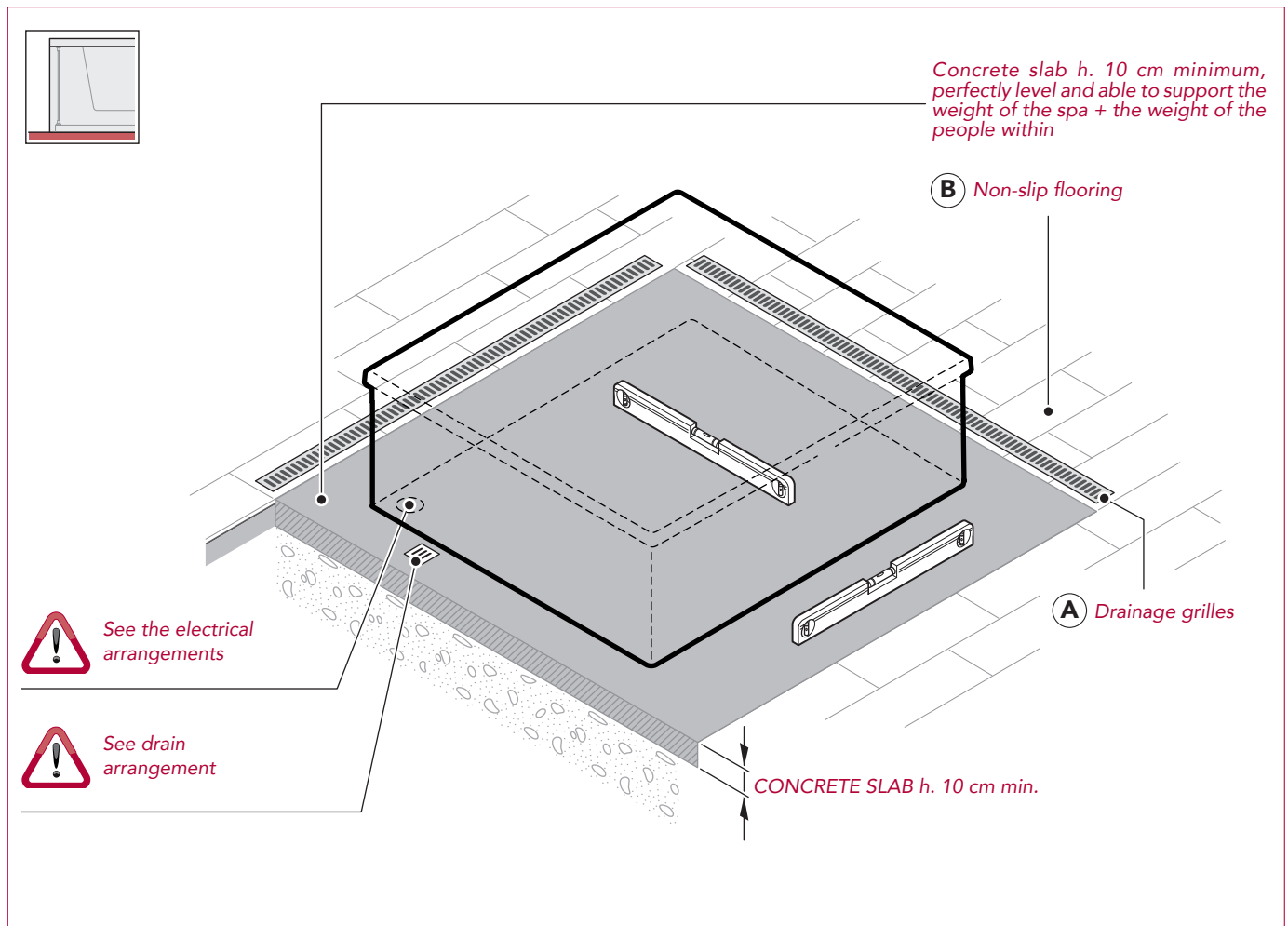

BUILT-IN INSTALLATIONS

As a base, create an underground niche in reinforced concrete, with a minimum thickness of 10 cm, perfectly flat and suitable to support the weight of the spa and its guests. The company recommends a minimum load of 400 kg/m². In any case contact a qualified construction engineer to calculate the appropriate load for your installation site.

 Wedges or shims cannot be placed under the spa to level it.
Remember to ground the structural reinforcement in accordance with electrical codes.

Prepare:

- **(A)** A technical inspection port* at least 50 cm wide on all sides of the spa. This will make future maintenance or repairs easier.
- **(B)** drainage grating around the perimeter and in the recess to help preserve the equipment and the structure (even for indoor installations).
- **(C)** A non-slip flooring around the spa.
- **(D)** Two Ø15 cm vents to ensure proper ventilation and extraction of the heat and moisture from the technical compartment.

FOR THE RECESSED OUTDOOR INSTALLATIONS, to avoid damage due to freezing we recommend insulating

(E) the spa recess. This procedure prevents excessive condensation that over time cause odours and damage to all major internal components. The choice of materials

and thickness should be based on the minimum temperatures reached in the country of installation.



For the preparation of the electrical connections see the pertinent chapter on page 12.

* If it was not possible to provide a technical inspection port on all sides of the spa, a pneumatic lift is available (optional - to be requested from the Manufacturer) in order to simplify future maintenance operations. It is recommended to provide a removable inspection hatch "A" positioned on the side where the spa components are situated. Regarding the installation and use of the lifter, refer to its technical sheet and manual.

After positioning the spa in its prepared space and after having connected the lift, test it.

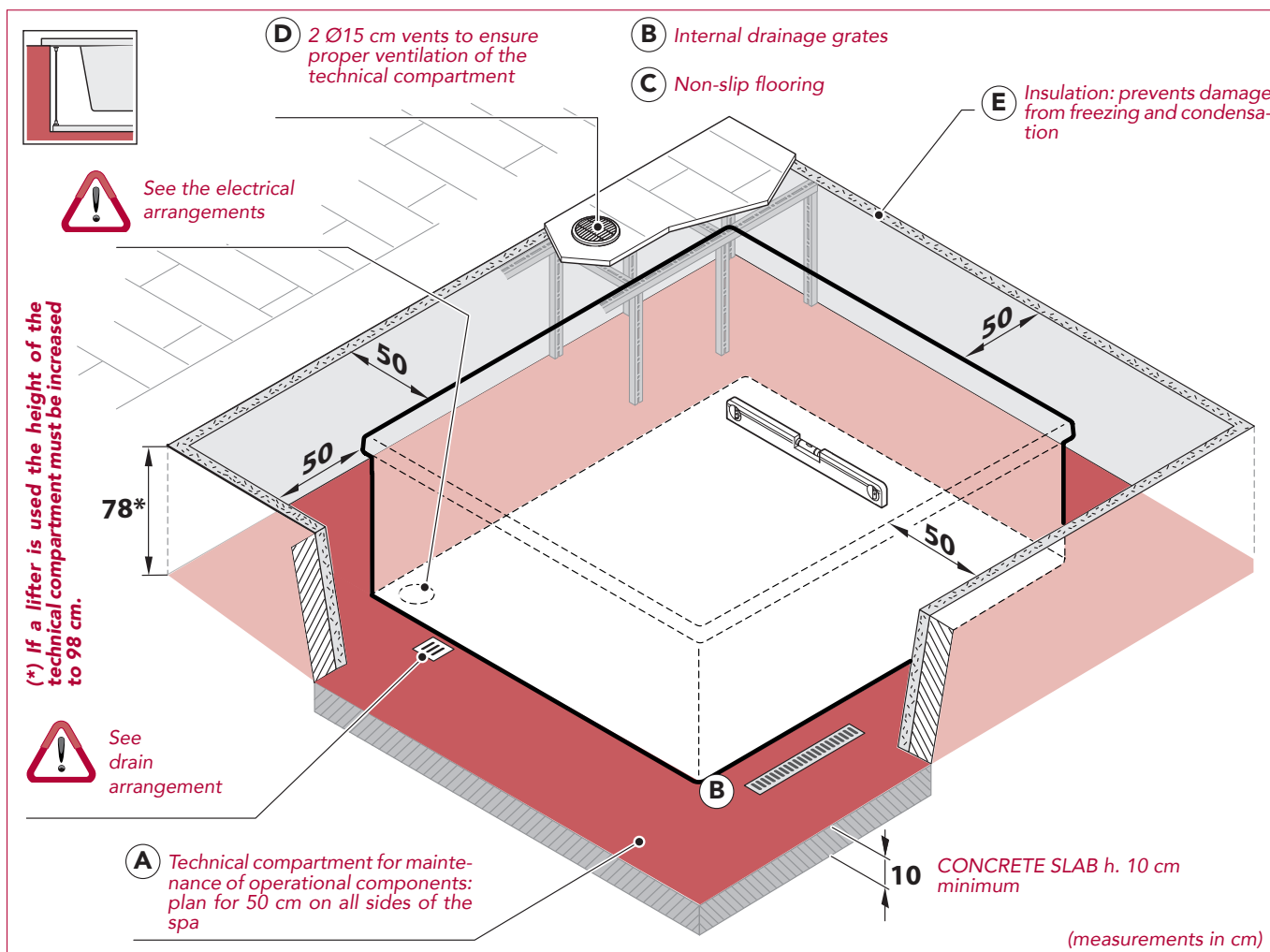
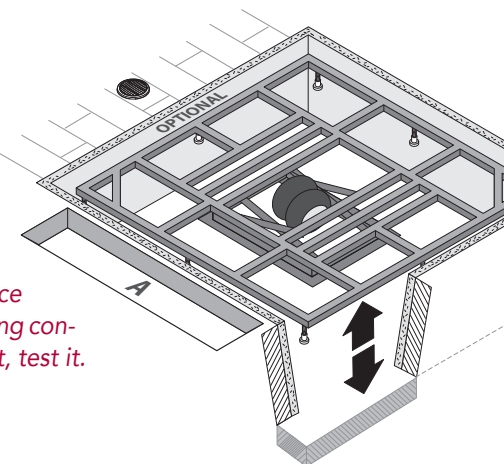

5 ELECTRICAL PREPARATIONS

The Tresse spas are built in compliance with UL laws (XXXXXXXX) and are tested during production to ensure the safety of the installer and user.

The connection must be made by an experienced, qualified electrician.

a) **READ AND FOLLOW ALL INSTRUCTIONS.**

b) A green coloured terminal or a terminal marked G, GR, Ground, Grounding, or the symbol* is located inside the supply terminal box or compartment. To reduce the risk of electric shock, this terminal must be connected to the grounding means provided in the electric supply service panel with a continuous copper wire equivalent in size to the circuit conductors supplying this equipment. * IEC 60417, Symbol 5019.

c) At least two lugs marked "BONDING LUGS" are provided on the external surface or on the inside of the supply terminal box or compartment. To reduce the risk of electric shock, connect the local common bonding grid in the area of the hot tub or spa to these terminals with an insulated or bare copper conductor not smaller than No. 6 AWG.

d) All field-installed metal components such as rails, ladders, drains, or other similar hardware within 3 m of the spa or hot tub shall be bonded to the equipment grounding bus with copper conductors not smaller than No. 6 AWG.

e) **SAVE THESE INSTRUCTIONS.**



The Manufacturer is not responsible for connections made in a way that does not comply with local codes, the specifications in this manual or tampering with any electrical component of the spa.

WARNING – This product is provided with a ground-fault circuit-interrupter (give location). The GFCI must be tested before each use. With the product operating, open the service door. When the product stops operating, this merely indicates that the door is equipped with an electrical interlock. Next, push the test button on the GFCI and close the service door. The product should not operate. Now open the service door, push the reset button on the GFCI and close the service door. The product should now operate normally. When the product fails to operate in this manner, there is a ground current flowing indicating the possibility of an electric shock. Disconnect the power until the fault has been identified and corrected.



Local regulations prohibit any electrical installation (plug sockets, switches, lamps, etc.) in the area surrounding the spa for a distance of at least 60 cm and a height of 230 cm.

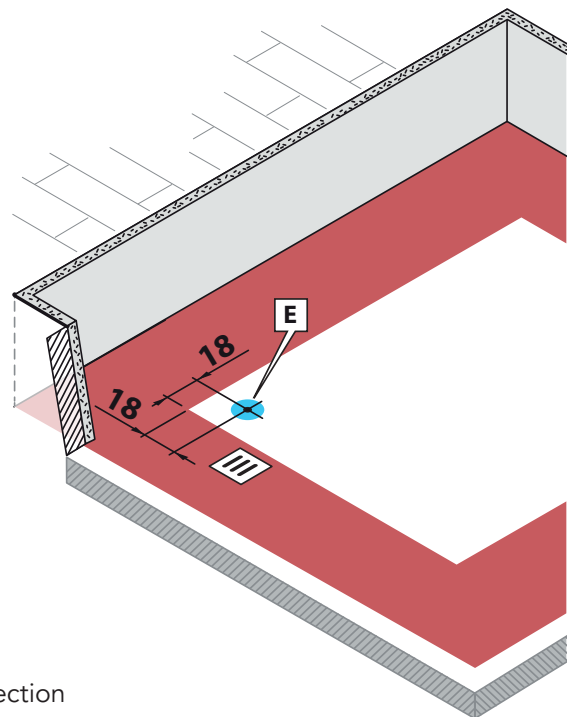
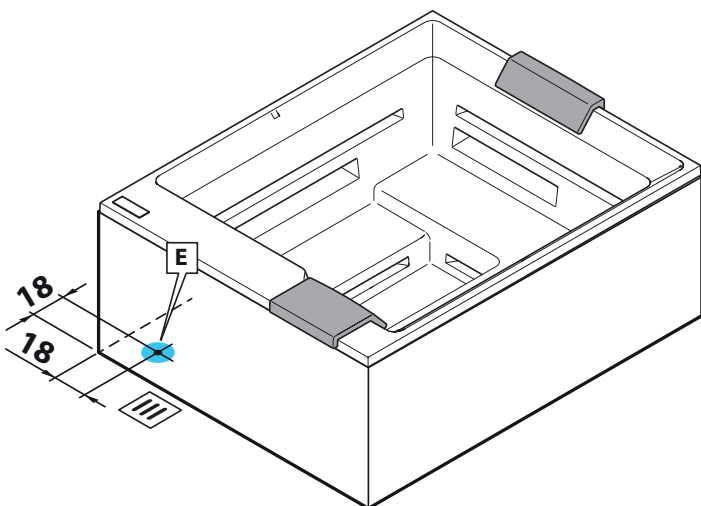
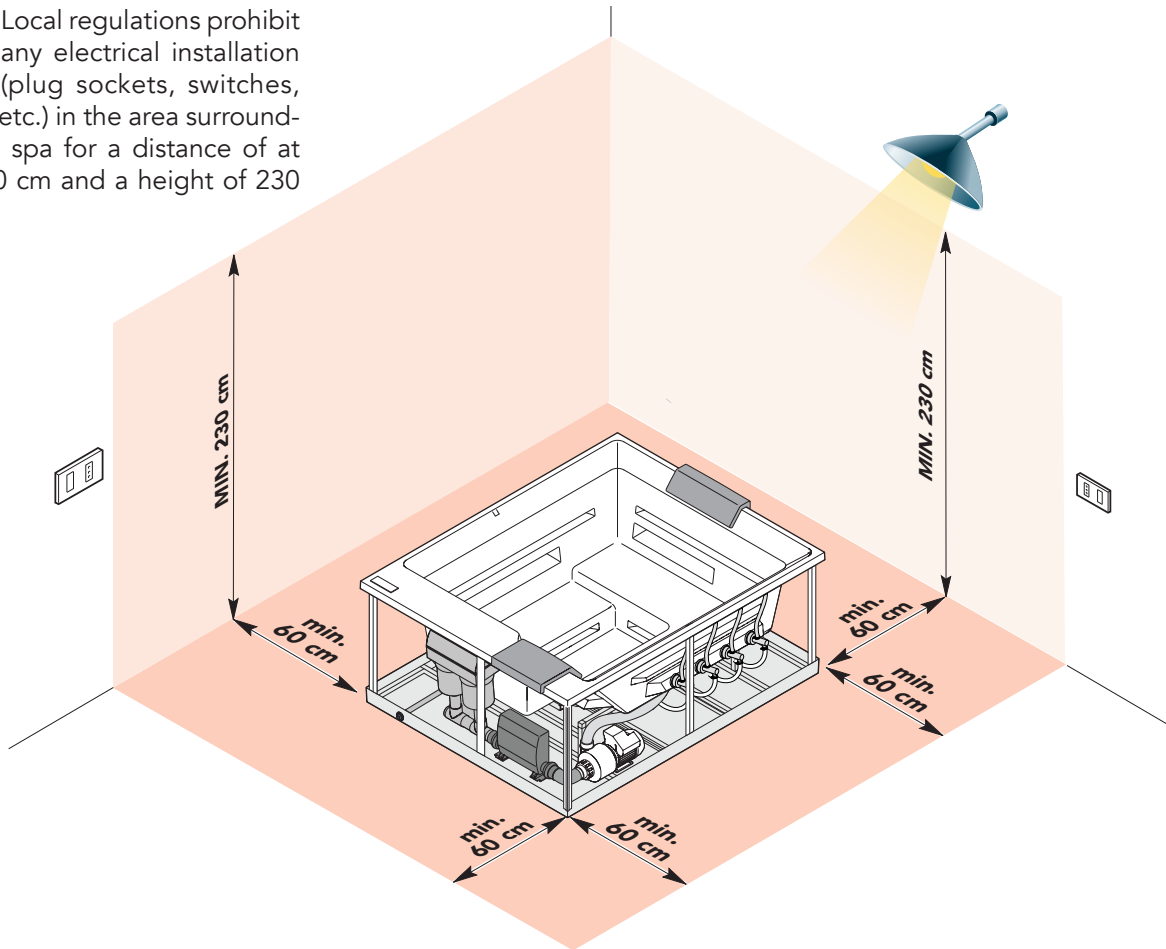

LEGEND

ⓔ Electrical connection

(measurements in cm)

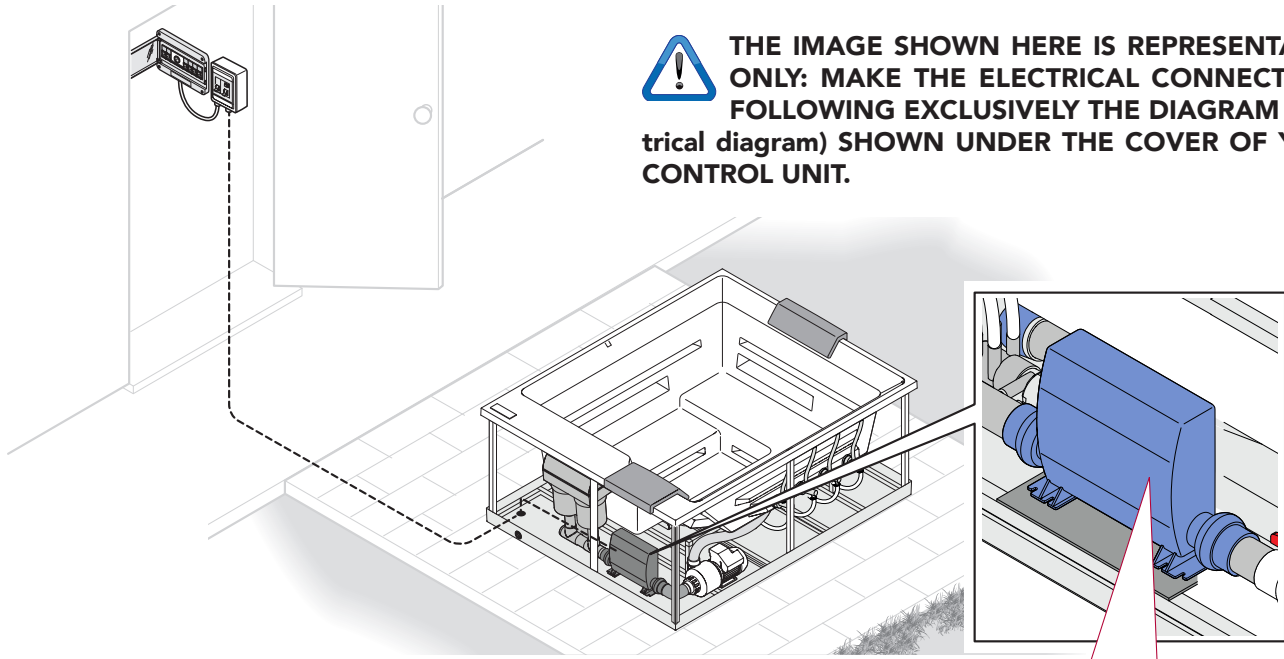

THE IMAGE SHOWN HERE IS REPRESENTATIVE ONLY: MAKE THE ELECTRICAL CONNECTIONS FOLLOWING EXCLUSIVELY THE DIAGRAM (electrical diagram) SHOWN UNDER THE COVER OF YOUR CONTROL UNIT.

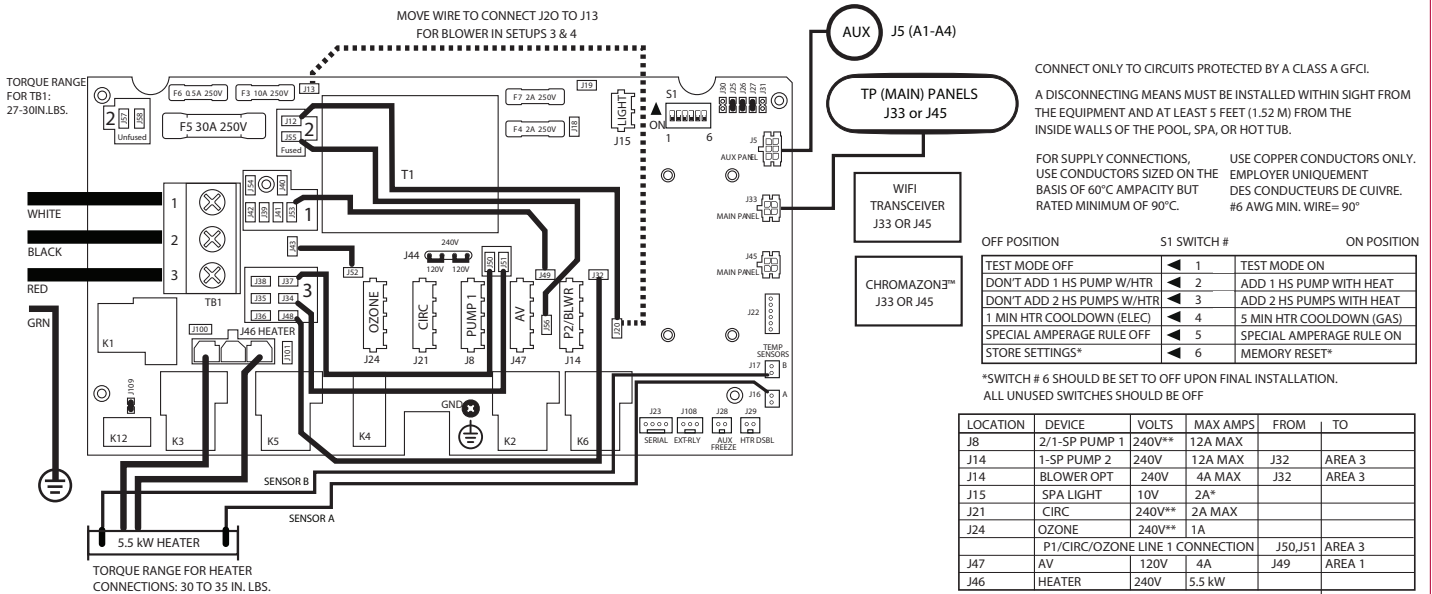

INSTEAD OF SETUP #1, THIS SYSTEM IS CONFIGURED IN SETUP #:

SETUP #	CIRC PUMP	PUMP 1	PUMP 2	PUMP 3	BLOWER	TEMP SCALE
1	NONE	2-SPEED	1-SPEED	NONE	NONE	°F
2	FILTERS + POLLING	1-SPEED	1-SPEED	NONE	NONE	°F
3	NONE	2-SPEED	NONE	NONE	1-SPEED	°F
4	FILTERS + POLLING	1-SPEED	NONE	NONE	1-SPEED	°F
5	NONE	2-SPEED	NONE	NONE	NONE	°F
6	FILTERS + POLLING	1-SPEED	NONE	NONE	NONE	°F

LOCATION	DEVICE	VOLTS	MAX AMPS	FROM	TO
J8	2/1-SP PUMP 1	240V**	12A MAX		
J14	1-SP PUMP 2	240V	4A MAX	J32	AREA 3
J14	BLOWER OPT	240V	4A MAX	J32	AREA 3
J15	SPA LIGHT	10V	2A*		
J21	CIRC	240V**	2A MAX		
J24	OZONE	240V**	1A		
J47	P1/CIRC/OZONE LINE 1 CONNECTION			J50,J51	AREA 3
J47	AV	120V	4A	J49	AREA 1
J46	HEATER	240V	5.5 kW		

**PUMP 1, CIRC AND OZONE ALL MUST BE THE SAME VOLTAGE.
* 2A LIMIT IS SHARED BY J15 SPA LIGHT AND CHROMAZON™

6

CHARACTERISTICS OF THE WATER SUPPLY**More information****TAP WATER AND WELL WATER**

To ensure maximum hygiene and durability of the spa it is essential to pay close attention to the quality of the water that will be used to fill it. It is important that the water used be drinkable. It is always advisable not to use well water because it may be very hard, rich in metals like iron and manganese, and have bacterial loads. Tap water is recommended.

In the case of very hard or ferrous water it is always recommended to install softening and iron removal systems upstream.

The company cannot be held responsible for issues related to the use of non-drinkable water or lack of installation of such systems.

The plumber is responsible for choosing the type of components to be used and the verification of compliance with the purity and potability parameters of the water supply.

WATER HARDNESS

Water hardness (TH) is determined by the total content of calcium and magnesium present in the water, coming from their soluble salts.

Water classification:

.....up to 7°f	= Very soft water
From 7°f to 14°f	= Soft water
From 14°f to 22°f	= Slightly hard water
From 22°f to 32°f	= Fairly hard water
From 32°f to 54°f	= Hard water
.....more than 54°f	= Very hard water

(1°f = 10 mg calcium carbonate per litre of water)

WATER ALKALINITY

Alkalinity (CAT) represents the concentration of bicarbonate ions present in the water. It is expressed as mg/L of calcium carbonate or in French degrees (°F). Ideal values of alkalinity range between 80 mg/L and 125 mg/L (8°F-12.5°F). Values outside of this range can more easily cause variations of the pH. Instead, alkalinity within the range noted makes it possible to "buffer" the pH value, resulting in fewer abrupt variations.

WATER PH**What is pH?**

The pH is a chemical parameter that gives an idea of the acidity or basicity of the water. It can assume values between 0 and 14. By definition water is considered neutral if its pH is equal to 7. It is acidic if the pH is lower than 7 and basic if the pH is greater than 7. Disinfectants have an ideal pH at which they are most effective. In the case of heated water treated with bromine products it is recommended to keep the pH value in the range from 7.4 to 7.8 using chemical correctors as needed if the pH is higher or lower to bring the pH value back to the recommended interval.

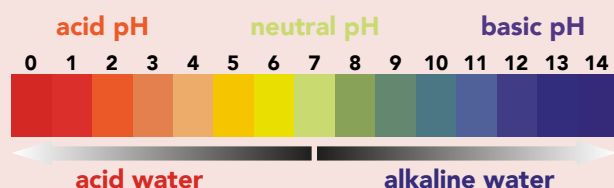

CHARACTERISTICS OF THE WATER SUPPLY

PARAMETER	OPTIMAL VALUES between...	VALUES ABOVE OR BELOW CAN...
POTABILITY	Refer to the specific regulations of the country of use	...cause problems related to the safety and well-being of users
HARDNESS (TH)	between 10°F and 25°F (100 mg/l-250 mg/l)	...cause build-up that over time can cause damage to the walls of the spa, the pipes, the filter system, as well as the heating unit and pumps. The limescale deposits can also hide bacterial loads that are not easily reached by disinfectant products. Installation mandatory. It is mandatory to install a <u>cation exchange resin water softener</u> , choosing the model according to the hardness of the water.
pH	for bromine treatments it is recommended to keep the pH in the range 7.4 to 7.8	...irritation of the eyes and skin of people in the water, water with little sanitising power, excessive consumption of chemicals, decrease in the duration of the spa components.
ALKALINITY (CAT)	80 and 125 mg/l (8-12.5°F)	...more likely uncontrollable changes in pH

Maximum care has been paid to guarantee the accuracy of this manual.

The Manufacturer reserves the right to modify the equipment or the documentation at any time, without notice.

Therefore there might be small differences between this manual and the product you have received: we apologise in advance for any inconvenience.

The total or partial reproduction of this manual without the Manufacturer's consent is prohibited. Measurements are purely indicative and not binding.

The original language of this manual is Italian: the Manufacturer is not responsible for any mistakes in translation/interpretation.

treesse

www.gruppotreesse.it

GRUPPO TRE S.p.a.
01036 Nepi (VT) - Italy
S.S. Cassia km. 36.400
Settevene industrial area
tel. (+39) 0761 527242
fax (+39) 0761 527223
info@gruppotres.it